The City of Sydney Exterior Lighting Strategy



Table of Contents

	Page No
I Introduction	I
1.1 Recent Initiatives	1
1.2 Exterior Lighting Strategy	1
1.3 Objectives	2
2 Exterior Lighting Categories and Locations	3
3 Lighting of Public and Pedestrian Spaces	5
3.1 Introduction	5
3.2 Pedestrian Lighting Objectives	6
3.3 Techniques and Standards	7
4 Street Lighting	8
4.1 Introduction	8
4.2 Street Lighting Objectives	9
4.3 Techniques and Standards	10
5 Lighting of Trees and Landscape Features	11
5.1 Introduction	11
5.2 Lighting Objectives for Trees and Landscape Features	11
5.3 Techniques and Standards	12
6 Decorative Lighting	13
6.1 Introduction	13
6.2 Decorative Lighting Objectives	14
6.3 Locations	15
6.4 Techniques and Standards	15
6.5 Laser and Search Light Displays and Film Production Lighting	17
7 Controls for New and Upgraded Building Lighting	19
7.1 Under-awning Lighting	19
7.2 Building Facade Lighting	20
7.3 Illuminated Signs	22
7.4 Roof-top Illumination	24
8 Compliance with Environmental Guidelines	25
9 Compliance with Australian Standards	26
10 Maintenance and Asset Management Procedures	27
11 Glossary	28
Appendices: Smartpole™ Strategy and Approved Luminaires	30
A1 Smartpole™ Masterplan	
A2 Smartpole™ Installation Program Stages 1 and 2	
A3 Smartpole™ Specification	
A4 Approved Luminaires	

This strategy was adopted by the City of Sydney on 4th September 2000

© City of Sydney. All rights reserved. No part of this work will be reproduced, translated, modified, transmitted or stored in any form or by any means without the prior permission of the City of Sydney.

Enquiries regarding this document should be made in the first instance to:
The One Stop Shop
Town Hall House
456 Kent Street
Sydney

GPO Box 1591
Sydney NSW 2001
Tel: 02 9265 9255
Fax: 02 0265 9415
Email: public
affairs@cityofsydney.nsw.gov.au

Introduction

I

1.1

Recent Initiatives

In 1998 the City of Sydney commenced a major upgrading of exterior lighting, including:

- > the roll-out of the City's new Smartpole™ program to achieve high quality functional lighting in the public realm;
- > improvements to existing lighting in laneways;
- > the installation of decorative lighting in various precincts for public enjoyment and public communication;
- > the introduction of the Safe City strategy, part of which focuses on lighting for pedestrian safety and the introduction of closed circuit video surveillance; and
- > the inclusion of conditions of consent in development applications for illuminated signage, exterior lighting of buildings and under-awning lighting.

1.2

Exterior Lighting Strategy

Following these initiatives, the City of Sydney has developed **The City of Sydney Exterior Lighting Strategy**. This document contains the objectives, strategies and standards for lighting of the public domain for the City of Sydney.

Under **The Exterior Lighting Strategy** the City of Sydney will carry out further work to establish:

- > An **Exterior Lighting Inventory** of all exterior public lighting with details of locality, ownership, asset description and asset management, cleaning and maintenance regimes. This will be a live document to be updated on a regular basis and will be an essential database for use by the City of Sydney and Energy Australia.
- > An **Exterior Lighting Implementation Plan** that will include detailed lighting designs for precincts, linked to the City's capital works programs, with specifications for installation, operation and maintenance.

Objectives

The overall objectives of **The Exterior Lighting Strategy** are:

- > to improve the illumination of the City of Sydney at night to ensure public safety, public enjoyment, architectural appreciation, and night-time entertainment
- > to establish the City of Sydney as Australia's premier city and one of world recognition for the lighting of the public realm
- > to create a greater sense of civic pride in the City at night, encouraging more frequent visits by residents and tourists
- > to seek an expression of Australian and Sydney City culture and custom, to mark Sydney's unique role as a gateway destination and to give emphasis to the character of individual precincts within the City
- > to provide best practice guidelines for exterior lighting design
- > to implement high environmental lighting standards, including the use of sustainable energy where feasible, in order to
 - i) prevent an increase in 'sky glow', which affects the clarity of astronomical observations, and
 - ii) conserve energy and minimise the unnecessary emission of greenhouse gases
- > to promote a glare free environment for traffic and pedestrians
- > to utilise the latest technology for effective conversion of light into illumination
- > to create an aesthetic appearance for night-time illumination and lighting infrastructure during daylight hours.



Exterior Lighting Categories and Locations

2

The Exterior Lighting Strategy covers the following elements:

Lighting of Public and Pedestrian Spaces

- > Lighting for pedestrian safety in plazas, parks and laneways
- > Lighting to enhance the beauty and use of public spaces at night

Street Lighting

- > Smartpole™ installations
- > Other street light installations

Lighting of Trees and Landscape Features

- > Lighting of trees, foliage and natural features in parks and public places

Decorative Lighting

- > Themed lighting for major events – large area locations
- > Themed lighting for local pedestrian precincts
- > Lighting of heritage buildings
- > Decorative illumination of buildings and structures including construction sites and hoardings
- > Decorative lighting of City artworks, decorations and sculptures
- > Special communications/messages in lighting

Development Controls for New/Upgraded Building Lighting

- > Under-awning lighting
- > Building façade lighting
- > Roof-top illumination
- > Illuminated advertising signage

The Exterior Lighting Strategy applies to those parts within the boundary of the City of Sydney that are under the City's control.

The City of Sydney will encourage the use of **The Exterior Lighting Strategy** guidelines in the areas within its boundary that are not under its control, in order to ensure a degree of overall uniformity of appearance and long term maintenance benefits. The City will liaise with public authorities controlling these areas, including Sydney Harbour Foreshore Authority, Royal Botanical Gardens and Domain Trust, Darling Harbour Authority and Sydney Opera House Trust.

In certain circumstances exterior lighting is provided by the private sector as a condition of development consent for building and under-awning illumination. The City will welcome discussions at the early stage of design development in order to achieve the delivery of effective, safe and efficient exterior lighting schemes.

The City of Sydney will include Energy Australia and the Roads and Traffic Authority of NSW in its liaison with the public and private sector organisations, particularly in respect to delivery, operation and maintenance issues.



Introduction

There is a wide variation of pedestrian lighting in the City of Sydney, established at different times in the City's growth and at different stages of lighting technology.

Two imperatives have led to the upgrading of standards for public and pedestrian areas - the need for a higher level of pedestrian safety and the desire to improve the quality of the pedestrian environment at night. The City of Sydney's Safe City strategy stresses the importance of adequate lighting levels as a key crime prevention measure, contributing to the reduction in crime and the increase in the public's perception of safety.

In 1997 the City commenced a program to upgrade lighting in the public domain in order to improve visibility for traffic and pedestrians, increase public safety and enhance the aesthetic look of the City. The Smartpole™ was designed to provide the new infrastructure, capable of delivering pedestrian and street lighting, and performing a multi-functional role for audio/visual equipment, traffic signals, signage and banners.

To date, 750 Smartpoles™ have been installed in the City. Of this total, 370 deliver illumination for traffic and pedestrians along the major streets and adjacent footpaths and half of these also support traffic signals. A further 80 have been installed exclusively for pedestrian illumination and another 50 exclusively for traffic signals. Newly upgraded pedestrian plazas, lit by the Smartpoles™, are along Alfred Street, in Customs House Square and in Martin Place.

In previous years, different pedestrian lighting designs were installed in parks and plazas. These are to be maintained, however the objective of the Strategy is for all future installations, where appropriate, to employ the Smartpole™ design. In parks and public spaces lights will be selected with consideration given to continuity across the City, environmental concerns and maintenance requirements. The Louis Poulsen design has been installed in Pymont, the "Macquarie Street Special" light standard along Macquarie Street, and the "Rocks" light standard around the Circular Quay promenade and in The Rocks.

In 1998, the City commenced its Safe City strategy by installing a network of street safety cameras, that are monitored 24 hours a day, for areas where there is a high concentration of crimes against the person, such as assault and robbery. This equipment requires specific illuminance levels and colour quality standards, and these have been taken into account in upgrading the lighting.

The public and pedestrian lighting standards, set out below, apply not only to areas used exclusively by pedestrians, but also to areas where there is a mix of pedestrians, vehicles and cyclists.

Public and Pedestrian Lighting Objectives

The objectives for public and pedestrian lighting are:

- > to illuminate public and pedestrian areas in the City, including street footpaths, to a standard that provides a safe and comfortable visual environment for pedestrians at night
- > to illuminate public and pedestrian areas in the City to a level that will reduce the risk of crime to people and property
- > to provide a level of illumination in high risk areas which is adequate for video surveillance
- > to enhance the aesthetic quality of public and pedestrian spaces through skilful design and location of the pedestrian lighting networks
- > to provide light sources that give a natural appearance to people and surroundings, with good colour rendition
- > to utilise the latest technology in the design of luminaires to ensure:
 - i) maximised efficiency
 - ii) prevention of glare, blind spots and excessive spill light caused by unshielded light sources.



Chifley Square



Customs House Square



Alfred Street, Circular Quay

Techniques and Standards

(For definition of terms, see Section 1.1: Glossary).

The minimum standard required for the lighting of all public and pedestrian areas, including footpaths on streets, is to comply with the new Australian Standard AS/NZS 1158 3.1:1999 Pedestrian Area (Category P) Lighting.

For a satisfactory video camera performance, a minimum vertical level of illumination back to the camera of 4 lux at a height of 1.5m is required.

Where the canopy of street trees or building awnings obstruct the light from the main street lighting luminaires, separate pedestrian luminaires are to be installed to provide the necessary illumination to meet the relevant Australian Standard.

Metal halide light sources are to be used, providing a warm natural appearance to people and surroundings, approaching daylight quality colour renditions. For a safe, comfortable pedestrian environment, a correlated colour temperature of 3000K with a minimum Colour Rendering Index (CRI) of Ra 80 is required.

A program to replace the heads of existing post-top luminaires with controlled, glare free light fittings is to be implemented. This will reduce unwanted obtrusive light and spill light.

For pedestrian bridges and underpasses, increased levels of illumination are required to overcome the inherent insecurities associated with these structures and to dissuade vandals from causing damage. The performance parameters detailed in the new Australian Standard AS/NZS 1158 3.1:1999 Pedestrian Area (Category P) Lighting are to apply to all such installations.

Street Lighting

4

4.1

Introduction

Until 1998, street lighting in the City of Sydney was mainly delivered by the infrastructure installed, operated and maintained by Energy Australia, on behalf of the City. (In the last 15 years, some additional small lighting schemes, using non-standard designs, were installed in local areas and maintained by the City.)

With the design and installation of the Smartpole™ in 1997-8, the City has achieved a significant improvement in street lighting. Five versions of the Smartpole™ have been manufactured for application to different traffic and pedestrian conditions.

The first stage for the rollout of 500 poles is to be completed by the end of 1999 and a second stage, to install a further 550 poles, is targeted for completion by the Olympics in 2000. By then street lighting in more than half of the City Centre will have been upgraded.

The City of Sydney has entered into an Agreement with Energy Australia to take over the asset ownership of Smartpoles™ and to carry out the installation of the second stage of the Smartpole™ program. All Smartpoles™ and all existing Energy Australia poles will be owned, maintained and operated by Energy Australia, on behalf of the City of Sydney.



Street Lighting Objectives

The objectives for street lighting are:

- > to illuminate the City's streets to a level that provides high visibility for pedestrian and vehicular safety, by
 - i) completion of the Smartpole™ program, and
 - ii) upgrading of all other existing street lighting, utilising an approved metal halide traffic route luminaire
- > to upgrade the illumination of all laneways to the relevant Australian Standards, utilising the suite of approved luminaires
- > to install separate pedestrian luminaires where the canopy of street trees obstructs the light from the main street lighting, in order to meet the correct illumination standard
- > to utilise the latest technology in the design of the luminaires to provide for
 - i) maximised efficiency
 - ii) precise light distribution which prevents spill light and associated glare
- > to upgrade the lighting structures in the City to a standard of design excellence
- > to minimise street furniture clutter through the installation of the multi-functional Smartpole™, which is designed to accommodate traffic signalling, street signage, banners, banner lighting, video surveillance, special signage and other audio/electrical applications
- > to incorporate the Smartpole™ into all capital works upgrading programs for major streets and local precincts throughout the City, including installations in all privately developed projects where the infrastructure will be handed over for ownership or operation by a public authority.



Techniques and Standards

The standard for the lighting of major streets in the City of Sydney is to be 30% above the minimum specified in the Australian Standard for Vehicular Traffic Lighting, AS/NZS 1158 1.1:1997 for Category VI Roads. The installation geometry shall be single-sided or double-sided, depending upon the light technical parameters. If this is impractical, advice should be sought from the City of Sydney. Major traffic route luminaires are required to have a cut-off light distribution characteristic.

For the upgrading of traffic route street lighting in areas where Smartpoles™ are not presently scheduled, semi cut-off luminaires (see Appendix 4 for approved luminaires) may be substituted where existing pole installation geometry precludes the direct substitution of the City of Sydney approved Smartpole™ cut-off luminaire.

Standards of lighting for minor streets and laneways for pedestrian and vehicular safety are to comply with the relevant Australian Standard in AS/NZS 1158 3.1: 1999 Pedestrian Area (Category P) Lighting. These luminaires shall, at the minimum, comply with the Upward Waste Light Ratio characteristics specified in relevant Australian Standards, with preference for near cut off light distribution.

Where Safe City street safety cameras are installed, all luminaires shall have a cut off light distribution. It is preferable to mount the cameras higher than the pedestrian luminaires.

Metal halide light sources are to be used, providing a natural appearance to people and surroundings, approaching daylight colour renditions. For vehicular traffic routes a correlated colour temperature of 4000K with a minimum Colour Rendering Index (CRI) of Ra65 is required. In minor streets and laneways, where pedestrians comprise the major usage, metal halide lamps with a correlated colour temperature of 3000K and a minimum CRI of Ra80 are to be used.

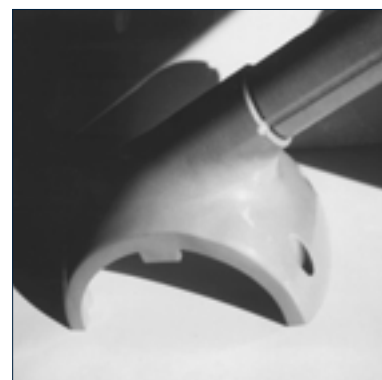
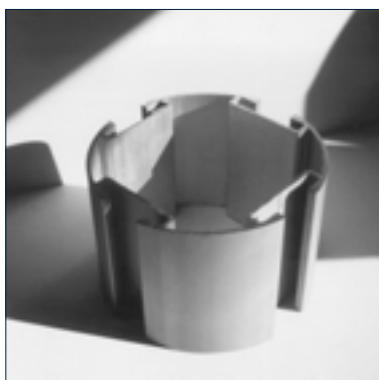

"Smartpole™" design components

Introduction

5.1

Trees and natural landscape features occur in many places throughout the City in prominent locations such as the Royal Botanic Gardens, in the City's parks and along the City streets.

Lighting of these natural elements creates a soft contrast to the intense built up environment and can create dramatic effects on the edges of the City, as seen from distant vantage points. Lighting of these elements also improves the pedestrians sense of safety after dark.

In 1998-99 the City's capital works program included the lighting of prominent trees and the sandstone cliff along the Tarpeian Way near the Opera House. In the City Centre in-ground lights have been installed to illuminate tree canopies as part of the public domain upgrading projects, in areas such as Chifley Square, Pitt Street Mall and Castlereagh Street.

Lighting Objectives for Trees and Landscape Features

5.2

The objectives for lighting of trees and landscape features are:

- > to emphasise prominent locations within the City by the lighting of trees and natural landscape elements
- > to create a heightened awareness of space in City squares and streets by the lighting of the underside of tree canopies
- > to create an informal contrast to the built environment by the illumination of trees, particularly on the fringes of the City Centre parks
- > to use lighting techniques designed to minimise light spill by focussing on the trunk and underside of the tree canopy
- > to create special effects by the downlighting of tree canopies and foliage in selected locations in the major peripheral parklands
- > to ensure that separate pedestrian luminaires are installed to produce the correct pedestrian illumination standard that is not dependent on the decorative lighting of trees and landscaping features

Techniques and Standards

Foliage illumination is to contrast to the pedestrian lighting, generally using a higher colour temperature, or whiter light, to emphasise green colours. Subtle coloured light may be used to illuminate foliage in selected locations. (The comparable pedestrian lighting design to create a safe, comfortable pedestrian environment, is to use warm metal halide light sources with a correlated colour temperature of 3000K with a minimum colour rendition of Ra 80.)

Where uplighting is used, luminaires with just sufficient beam spread and light output are required, coupled with accurate aiming, to define the trunks and capture the underside of the canopy in order to reduce waste upward light. Trees for uplighting should be carefully selected, the most suitable being those with dense canopies, in order to trap the light well.

Where uplighting techniques are employed with deciduous trees, the luminaires are to be capable of being switched off when the leaves have fallen. Suitable switching arrangements to accomplish this are to be incorporated in the electrical design.

Care should be taken to ensure that all uplighting installations comply with the intensity limitations described in AS4282: 1997 Control of the Obtrusive Effects of Outdoor Lighting.

Opportunities for using green energy sources for landscape lighting should be investigated.



Decorative Lighting

6

6.1

Introduction

Over many years the City Centre has been deserted at night with the evening exodus of office workers. However, with the increase in inner-city living and tourism and the expansion of entertainment activities, the City is becoming alive again at night. Celebrations, such as New Year's Eve, Sydney Festival, the Olympics, Paralympics and Centenary of Federation, attract large crowds into the City.

In 1998 the City initiated a decorative lighting program at Sydney Cove, including colour washing of strategic building facades and projected images. These installations are capable of being choreographed to create changing effects.

Temporary decorative lighting, associated with special events, can create temporary theatrical displays for cultural and civic festivities. These events involve the citizens of Sydney as well as being drawcards for tourists.

The City of Sydney has also installed permanent decorative lighting in several precincts of the City. Discrete lighting of heritage facades enhances Sydney Town Hall and the Queen Victoria Building. In Chinatown and at Railway Square new decorative lighting sculptures span the roadways.

A key objective of decorative lighting is to ensure that the dramatic effects do not result in a deterioration of the environment through wasteful spillage of light into the night sky.



Colour washing of facades - AMP Building and Museum of Contemporary Art

Decorative Lighting Objectives

The objectives of decorative lighting are:

- > to present to the world at night a City that is exuberant, dynamic and culturally rich, through the use of decorative lighting effects
- > to mount temporary spectacular lighting displays for major events such as the Sydney 2000 Olympics and Paralympics and the Federation festivities
- > to install permanent decorative lighting to enhance the heritage and contemporary architecture of City buildings
- > to use decorative lighting design to convey a unique sense of place to City precincts
- > to light the City's public artworks, sculptures and memorials in order to create a sense of prominence and history and to establish night-time landmarks
- > to use innovative decorative lighting techniques to control the obtrusive effects of exterior lighting and minimise excessive spill light into the night sky.



Obelisk



Queen Victoria Building



AMP Tower

6.3

Locations

The City is viewed at two levels – the 'macro' and the 'micro'. Decorative lighting can enhance both experiences.

The macro views are the long distance views of the City from across the water to the City skylines. Prominent natural waterfront headlands and parks are also often viewed from a distance. The City's gateways, seen as one approaches the City by road, rail or ferry, are key opportunities for special decorative lighting sculptures.

The two principal locations for the staging of major events and associated special light shows are at Circular Quay and Darling Harbour on the edges of the City, set against the background of the City's macro image.

The micro views are the intimate experiences of pedestrians walking through the City. Precincts have their own characters, such as the cultural precincts of Chinatown and the Spanish Quarter and the entertainment centres of George Street and Darling Harbour. There are special heritage precincts, such as Town Hall, The Rocks, Macquarie Street and Bridge Street precincts.

Night time views of parks, sculptures and street vistas also contribute to the micro experience of the observer.

Where there are construction sites the decorative illumination of structural elements and the surrounding hoardings can add to the vitality of a precinct that is under redevelopment and lacks activity.

6.4

Techniques and Standards

There are many innovative techniques for decorative lighting. In selecting appropriate techniques, the following principles are to be followed:

- > Permanent decorative lighting installations at the macro view are to be capable of augmentation and change for the staging of special events.
- > Concept design at the macro level is to encompass all decorative lighting elements in the field of view, including the 'capping' of buildings with light, decorative lighting effects on the water's edge, the lighting of prominent landscaping features and colour washing and image projection on to building facades.
- > For the illumination of heritage buildings the controlled and precise use of light by small sources and fine optics is important so that architectural details are accented and light is only used where it is needed. In this way the texture of buildings will be pronounced, giving depth to the form of the City and eliminating unwanted spill light.
- > Light sources installed on heritage buildings are to be incandescent in appearance with a colour temperature range of 2500k - 3200k to give a warm glow to the historic architecture.

- > Colour washing of facades is achieved by downlighting or narrow beam uplighting, with profiling techniques to minimise stray light into the night sky. Where possible the use of automatic retractable lighting structures concealed on rooftops is desirable.
- > Decorative lighting is to comply with the standards set out in the Australian Standard AS4282: 1997 Control of the Obtrusive Effects of Outdoor Lighting. Where it is considered appropriate curfews will be applied, in order to conserve energy and to minimise the adverse impact on astronomical observations.

For special events the following techniques could be implemented:

- > Decorative lighting effects, including colour scrolling and projected images, capable of being choreographed through an integrated computer control system.
- > Temporary lighting installations by artists and designers, including illumination of floating forms, suspended banners and sails.
- > For prominent heritage buildings, such as Sydney Town Hall, coloured filters fitted to the heritage lighting to change the colour effects for special events.
- > Laser displays and similar high powered projection systems, subject to strict air safety regulations as set out in the following section.

Techniques that are not considered appropriate for the City of Sydney include:

- > Budlights and similar festoon lighting on buildings which detract from the architectural qualities.
- > Broad floodlighting of facades from large light sources located remotely from the building.
- > Uplighting of flag poles/banner poles

All decorative lighting proposals are to be submitted as Development Applications to the Director of Development for development and construction certificate approval under the Central Sydney Local Environmental Plan 1996; Central Sydney Development Control Plan 1996; State Regional Environmental Plan No.26, Sydney Regional Environmental Plan No.26 - City West, and the Environmental Planning & Assessment (Amendment) Act 1997.

All Development Applications will be referred to the Director of City Projects.

The Development Application is to include photomontages or computer modelling of the effects, a statement of environmental impact and full details of the equipment to be used, supported by quantified technical data required by Australian Standard AS4282: 1997 Control of the Obtrusive Effects of Outdoor Lighting. The consent authority may require pilot testing prior to the issuance of development consent.

The purpose of decorative lighting is to enhance civic pride in the City and as such, no advertising is to be incorporated in the decorative effect. Where advertisers seek to display corporate promotional material in an illuminated form, the application is for an "Illuminated Sign" under Section 7 of this Strategy.

6.5

Laser and Search Light Displays and Film Production Lighting

A Development Application shall be submitted for laser and search light displays, for advertising and entertainment and for film production lighting, stating:

- > the form, content and hours of operation of the sign or display,
- > specification of the projection apparatus, and
- > the proposed screen or use of building as a screen, including projection onto clouds or water spray.



The following conditions are to apply to laser and search light displays and, where applicable, to film production lighting:

- > Displays will only be permitted for special events of community value/benefit.
- > The design and operation of the projector, laser beam, search light and screen shall be in accordance with all relevant Australian Standards, including the AS 4282: 1997 Control of the Obtrusive Effects of Outdoor Lighting.
- > The projected beam shall be a minimum of 4 metres above ground level and at least 3 metres from any window, door or other place accessible by humans.
- > The sign shall comply with the Roads and Traffic Authority's Advertising Strategy and the application shall be referred to the Authority for comment.
- > No building or structure identified as an item of Environmental Heritage shall be used as a screen.
- > The urban design is satisfactory.
- > The design and operation of the equipment shall comply with the standards of the **Civil Aviation Safety Authority's Manual of Operational Standards**. The application will be referred to this Authority for approval. The applicable standards and conditions are:

Clause 1.2 Assessment Criteria

Searchlight, laser and other powerful light displays or operations may be approved provided that:

- a. The light is not operated within five kilometres of an aerodrome.*
- b. The light is not directed at an aircraft.*
- c. Any searchlight is not directed below an angle of 45° to the horizontal.*
- d. The light operator has been instructed to inform the nearest air traffic control authority of the format and timing of the light display and of a telephone number for contact during the display.*
- e. The operator is informed that the Authority reserves the right to have the light extinguished at any time if it is considered that its continued operation is likely to endanger the safe operation of aircraft.*

Clause 1.3 Powerful Lasers

The above approval criteria apply to the normal range of industrial, entertainment or experimental lasers of the order of 20 watts continuous-wave power. More powerful machines may need to be dealt with by the provision of restricted airspace and a requirement for the laser operator to have observers to check for positive clearance from overflying aircraft.

Controls for New and Upgraded Building Lighting

Lighting proposals submitted for Development and/or Construction Certificate Approval are required to comply with the following development control policies:

7.1

Under-awning Lighting

In order to meet public security and safety objectives the illumination levels for under awning lighting are to comply with the pedestrian lighting requirements detailed in the Australian Standard AS/NZS 1158 3.1:1999 Pedestrian Area (Category P) Lighting.

To ensure easy identification of people and a feeling of safety emphasis is to be placed on the satisfactory achievement of vertical illuminance (being the amount of light falling onto vertical surfaces).

In order to standardise the lighting quality light sources are to have a correlated colour temperature of 3000K with a minimum Colour Rendering Index (CRI) of Ra 80.

The installation is also to meet the further requirements contained in **The City of Sydney Awnings Strategy 1998**, being that:

- > *lighting should be recessed, and/or integral to the awning's structure and form*
- > *associated wiring and conduits are to be concealed.*



Building Façade Lighting

The existing development controls in the **Central Sydney Development Control Plan 1996** are to apply to the external lighting of buildings, supplemented by the standards set out in **The Exterior Lighting Strategy** guidelines. The development controls are:

Clause 4.7 External Lighting of Buildings Strategy

The external lighting of buildings can add to the character of buildings at night and enliven the city skyline. However, external lighting has an impact on total energy efficiency and can affect residential amenity. In some cases it is more appropriate to highlight certain architectural features of a building rather than floodlighting whole facades.

Objectives

- > to encourage external lighting of buildings that adds to the architectural character of the building whilst having regard to efficient use of energy and the amenity of nearby residents
- > to keep spill light to a level that enables Sydney Observatory to continue to operate

Provision

4.7.1 Any external lighting of buildings is to be considered with regard to:

- i) the integration of external light fixtures with the architecture of the building (for example, highlighting external features of the building)
- ii) the contribution of the visual effects of external lighting to the character of the building, surrounds and skyline,
- iii) the energy efficiency of the external lighting system,
- iv) the amenity of residents in the locality,
- v) the impact on the night sky, having particular regard to observed effects from Sydney Observatory.

In addition to the **Development Control Plan** provisions above the principles set out in the decorative lighting section of **The Exterior Lighting Strategy**, for the lighting of building facades, are to apply, including:

- > Care is to be taken in the selection of buildings and methods of illumination to ensure that the City does not become over illuminated.
- > The intensity of lighting of individual buildings is to have regard to the ambient light conditions emanating from the building and in the surrounding precinct, to ensure that the proposal is not counter-productive.
- > Colour washing of facades is to be achieved by downlighting or narrow beam uplighting, with profiling to minimise stray light into the night sky. Where possible the use of automatic retractable lighting structures concealed on rooftops is desirable.
 - > For the illumination of heritage buildings the controlled and precise use of light by small sources and fine optics is important so that architectural details are accented and light is only used where it is needed. In this way the texture of buildings will be pronounced, giving depth to the form of the City and eliminating unwanted spill light.
- > Light sources used on heritage buildings are to be incandescent in appearance, with a colour temperature range of 2500k - 3200K to give a warm glow to the historic architecture.
- > Building façade lighting is to comply with the standards in the Australian Standard AS4282: 1997 Control of the Obtrusive Effects of Outdoor Lighting.



NRMA Building



Queen Victoria Building

illuminated Signs

The existing development controls in the **Central Sydney Development Control Plan 1996** are to apply to illuminated signs, supplemented by the standards set out in **The Exterior Lighting Strategy** below. The development controls are:

illuminated signs

8.1.19 *illuminated signs are to be beneficial to the liveliness of Central Sydney at night.*

8.1.20 *illuminated signs are not to detract from the architecture of the host building during daylight.*

8.1.21 *illumination (including cabling) of signs is to be:*

- i) *concealed, or*
- ii) *integral with the sign, or*
- iii) *provided by means of sensitively designed and located external spot lighting.*

8.1.22 *The ability to adjust the light intensity of illuminated signs is to be installed where the consent authority considers necessary.*

8.1.23 *A curfew may be imposed on the operation of illuminated signs where continuous illumination may impact adversely on the amenity of residential buildings, serviced apartments or other visitor accommodation, or have other adverse environmental effects.*

8.1.25 *Flashing or intermittently illuminated signs are generally not appropriate for reasons of pedestrian and residential amenity and traffic safety.*

Animated signs

8.1.27 *Animated wall signs are to be compatible with the building design, its use and the character of the locality.*

The supplementary guidelines in **The Exterior Lighting Strategy** for the floodlighting of signs are as follows:

- > For floodlight downlighting, suitable profile type luminaires are to be used to ensure complete elimination of waste spill and obtrusive light.
- > Use of upward aimed floodlighting is discouraged and shall not be permitted without technical data which demonstrates that there is no light waste spill or obtrusive light. Profile type luminaires are likely to be the most appropriate equipment to achieve this requirement.
- > Overall uniformity of the illumination of billboard type signage is to be maintained, being no greater than a ratio of 4:1 between the maximum to minimum levels of illumination.

- > The luminance (photometric brightness) of signs is to be in keeping with the background ie. a sign against the dark sky or dark surface should have a lower luminance than one on a light coloured facade.
- > The level of illumination of signs is to be assessed against the ambient light levels of the surrounding precinct.
- > Lighting should not cause either direct or reflected glare from normal viewing positions.
- > The daytime appearance of the flood lighting equipment must meet environmental standards and is not to cast significant shadow effects.
- > In general, neon, laser search light and moving illumination signage techniques will not be approved unless it can be clearly demonstrated that the application has particular merit for the locality and has no adverse environmental effects.
- > Temporary signage which is approved for an Olympic or Centenary of Federation event shall have regard to the Special Signage Provisions in the **Central Sydney Development Control Plan 1996**. A requirement of this Strategy is for these signs to comply with the Australian Standard AS4282: 1997 Control of the Obtrusive Effects of Outdoor Lighting.

Laser signs

- > Laser signs are subject to the standards and conditions set out in Section 6.5



Roof-top Illumination

Central Sydney Development Control Plan 1996 applies the following development control to roof and sky signs:

8.1.24 Uplighting of roof signs and sky signs is generally discouraged. Any external lighting of roof signs and sky signs is to be focused directly on the sign and is to minimise the escape of light beyond the sign.

The supplementary standards set out in **The Exterior Lighting Strategy** for roof-top illumination are set out below:

- > Care is to be taken in the selection of buildings and methods of illumination to ensure that the City does not become over illuminated.
- > The illumination of City buildings must be rationalised to effect a stronger, tidier appearance and in doing so create striking long-distance vistas of the City.
- > Close attention is to be paid to building capitals, as 'capping' the building with light creates a strong night-time skyline.
- > Techniques which minimise waste light and energy are to be employed.
- > Development Applications are to demonstrate, by photomontage, the effect in the field of view from distant vantage points.
- > Where uplighting is proposed evidence must be provided to demonstrate that no waste spill light or obtrusive light effects will result and that downlighting is not possible in the circumstances.

Urban 'sky glow' is the result of stray light, both direct and reflected, being scattered in the atmosphere and brightening the natural sky background level. This has the effect of concealing the stars in the spectacular Southern night skies in a haze of waste light.

The sky glow from Sydney is measurable from Australia's National Observatory at Siding Spring (near Coonabarabran). As this site is one of the two darkest observing sites in the world (the other being in Chile), it is important that in the national interest no further degradation of the night sky over Sydney occurs.

The generation of waste light also contributes to the production of greenhouse gases and increases energy consumption.

The City recognises that the urban environment of a large city has competing interests in creating an inviting night time environment for its residents whilst also minimising the sky glow effect. The lighting principles in **The Exterior Lighting Strategy** are designed to achieve the following environmental standards:

- > to minimise the escape of waste light into the night sky
- > to minimise unnecessary energy consumption
- > to promote a glare free environment for traffic and pedestrians
- > to utilise the latest technology for effective conversion of light into illumination
- > to create an aesthetic appearance for night-time illumination and lighting infrastructure during daylight hours.



Sydney's sky glow to be effectively controlled

Compliance with Australian Standards

9

All public lighting installations, including special decorative lighting and building and signage illumination, are to comply with :

- > Australian Standard AS/NZS 1158 Road Lighting (Parts 1, 2 and 3)
- > Australian Standard AS 4282: 1997 Control of the Obtrusive Effects of Outdoor Lighting

All luminaires used in these installations are to comply with relevant Australian Standards in respect to construction and safety.

All luminaires are to have test reports by the National Association of Testing Authorities (N.A.T.A.) certified photometric laboratories. All applications for lighting proposals are to provide copies of approved test reports. The design process, including the calculation process and software used, should be fully described and all information supplied in the relevant Development Application. Where the City considers it necessary, photometric data on computer diskette in IESNA format (Illuminating Engineering Society of North America) is to be supplied to enable independent appraisals to be carried out.

Maintenance and Asset Management Procedures

Properly maintained equipment is an essential prerequisite of all approved lighting installations. It not only is important from a civic appearance aspect but in many cases from public safety and security aspects.

All installations will decrease in effectiveness over time due to aging lamps and the soiling of the exterior of luminaires and reflectors. Aiming suffers due to factors such as vibration and poor adjustment after lamp replacement. These characteristics not only spoil the designed appearance but also waste energy.

The current practice for the maintenance of public lighting is to carry out a bulk replacement of lamps at the end of the effective lamp lifetime, taking into account the economic and operational characteristics of the lamps. Energy Australia's periodic bulk lamp replacement is targeted at 70% of lamp life.

At other times the current practice is to replace defective lamps upon notification of faults.

The City of Sydney's Agreement with Energy Australia is for Energy Australia to use its best endeavours to replace 90% of lamp failures within 24 hours of receipt of notification and to have all failed lamps replaced within 48 hours.

It is a City of Sydney strategy to initiate a new maintenance regime:

- > there will be regular inspections of the infrastructure to identify defects in lieu of ad hoc notification of faults

To ensure peak performance and energy conservation the following additional measures are required:

- > tree and plant growth is to be monitored and trimmed as required
- > where there are defective or vandalised fittings, the equipment is to be made safe and repaired in the minimum time reasonably possible (this requirement is to apply to all private and public sector signage and lighting installations)
- > Development Applications are to include maintenance plans for approval

In order to improve the illumination quality in the City, there is to be:

- > progressive replacement of existing lamps with metal halide lamps in all Energy Australia infrastructure in areas which do not have a priority in the "Smartpole™" program.

In this Strategy, the following definitions apply to the terminology:

Colour Temperature

In order to identify where the perceived colour of a light source lies in the range from cool (blueish) to warm (yellowish) it is usual to quote its correlated colour temperature (CCT) in degrees kelvin, with the symbol K. A low CCT such as 2700K will have a warm appearance whilst 6500K will appear quite cold.

Colour Rendering Index

The Colour Rendering Index relates to how accurately colours are revealed for a given colour appearance of a light source and is completely independent of the colour appearance of a light source. The Colour Rendering Index (CRI), is generally quoted as Ra, where 100 is perfect and anything above 80 is considered very good.

Floodlight

A floodlight is a specific form of luminaire that emits light within a limited range of direction, i.e. a beam.

Glare

Glare is the sensation of discomfort or impairment of vision experienced when parts of the visual field (such as poorly or unshielded bright lamps or luminaires) are excessively bright in relation to the general surroundings. The extent or severity of this sensation can be classified as follows:

- > Disability glare - glare that impairs the ability to see detail.
- > Discomfort glare - glare that causes visual discomfort without necessarily impairing the ability to see detail.

Illuminance

Illuminance is the amount of light arriving on a surface and is measured with the unit lux (lx).

Illumination

Illumination is the effect of illuminating a surface.

Luminance

The eye does not see light arriving on a surface but does see the effect of that form of energy reflected from an object or surface in terms of its photometric brightness or luminance. This is measured in candela per square metre (abbrev. cd/m²). The same illuminance falling on a light coloured surface will appear brighter than an identical amount falling on a dark surface.

Luminaire

The luminaire is the apparatus which distributes, filters or transforms the light transmitted from one or more lamps and which includes all the parts necessary for fixing and protecting the lamps, including the circuit auxiliaries for connecting to the electricity supply.

Obtrusive Light

Spill light is light that, because of quantitative, directional or spectral attributes in a given context, gives rise to annoyance, discomfort, distraction or a reduction in the ability to see essential information such as signs and traffic signals.

Sky Glow

Sky glow is the brightening of the night sky that results from the reflection of radiation (visible and non-visible), scattered from the constituents of the atmosphere (gaseous, molecules, aerosols, land particulate matter), in the direction of observation. It comprises two separate components as follows:

- > Natural sky glow – that part of the sky glow which is attributable to radiation from celestial sources and luminescent processes in the Earth's upper atmosphere.
- > Artificial sky glow – that part of the sky glow which is attributable to man-made sources of radiation (e.g. outdoor electric lighting), including radiation that is emitted directly upwards and radiation that is reflected from the surface of the Earth.

Spill Light (stray light)

Spill light is the light emitted by a lighting installation that falls outside the boundaries of a property or object to be lit and serves no purpose. If directed above the horizontal, spill light contributes directly to artificial sky glow.

A.1

Smartpole™ Masterplan

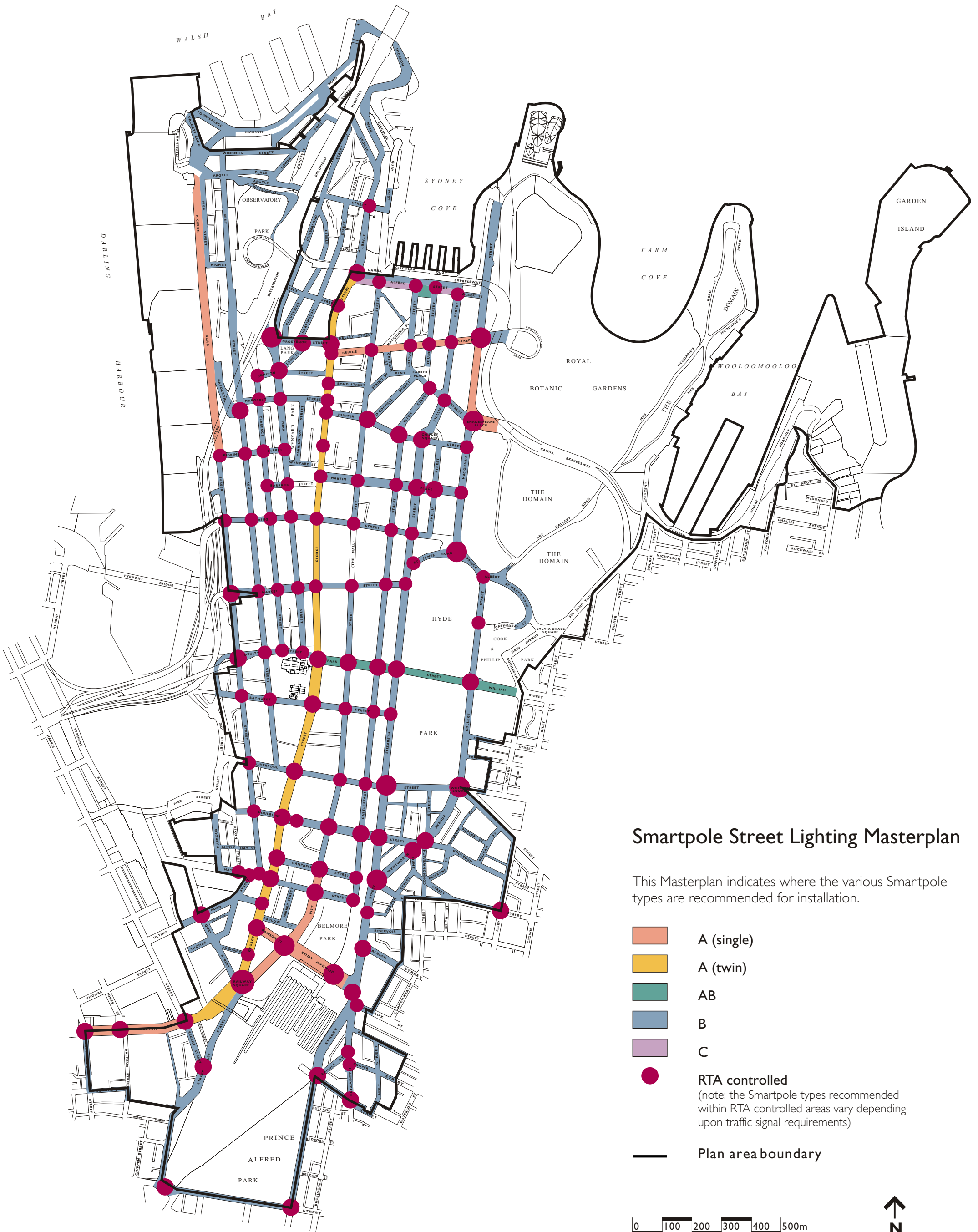

Smartpole Street Lighting Masterplan

This Masterplan indicates where the various Smartpole types are recommended for installation.

- A (single)
- A (twin)
- AB
- B
- C
- RTA controlled
(note: the Smartpole types recommended within RTA controlled areas vary depending upon traffic signal requirements)
- Plan area boundary

0 100 200 300 400 500m



A.2

Smartpole™

Installation Program

Stages 1 and 2

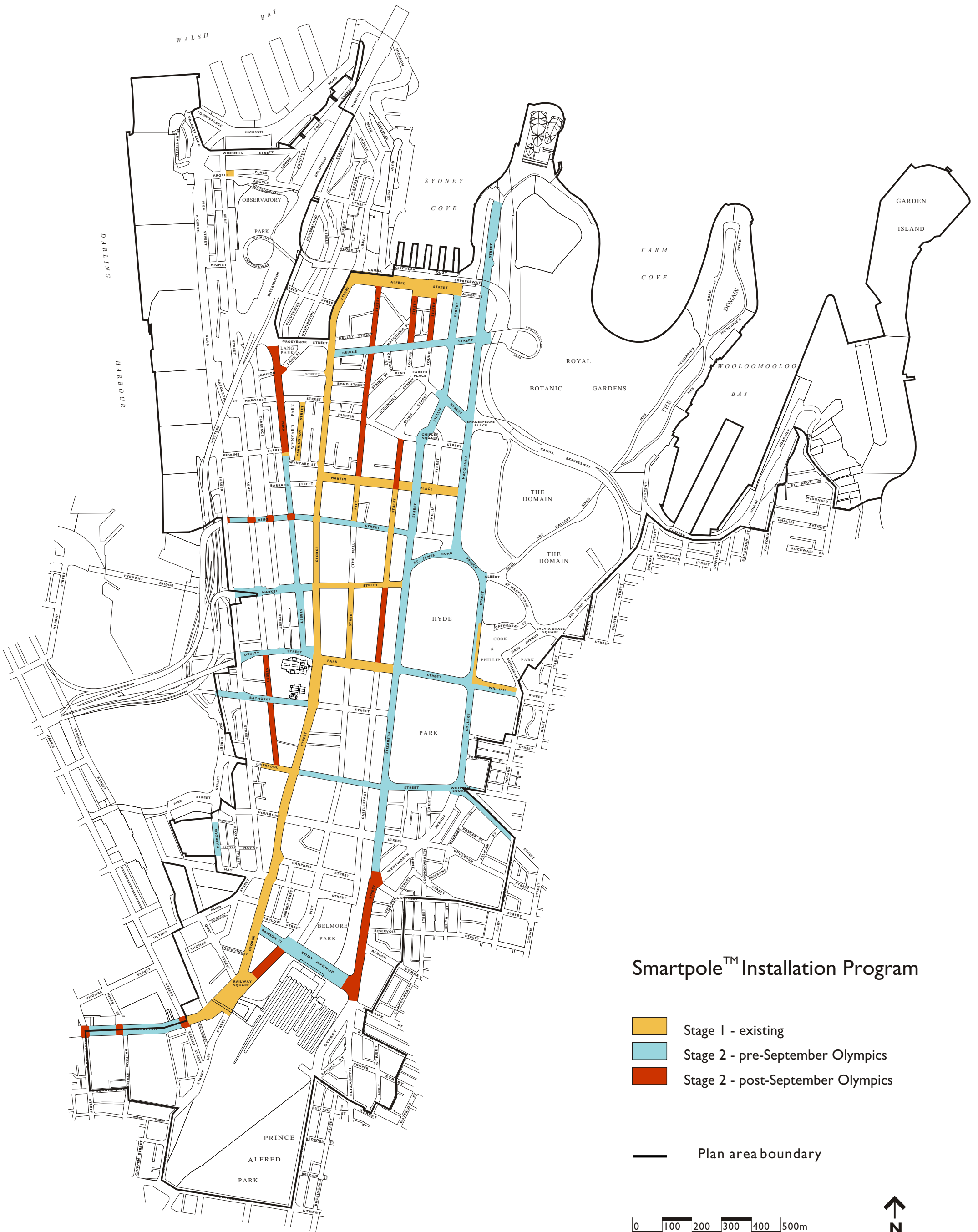

Smartpole™ Installation Program

- Stage 1 - existing
- Stage 2 - pre-September Olympics
- Stage 2 - post-September Olympics

— Plan area boundary

0 100 200 300 400 500m



A.3

Smartpole™ Specification

SMARTPOLE™



PRODUCT MANUAL

Part 1 System Overview Manual

Issue A
Ref 6400/700
Date 19.06.01



The Product Manual consists of the following parts;

Part 1- System Overview Manual (this Manual)

Part 2- Structural Certification Manual

Part 3 -Factory Assembly Manual

Part 4 -Installation Manual

Part 5 -Specification Drawings Manual

(A3 Reduced Scale Set for Reference Only)

TABLE OF CONTENTS

1.0 Introduction

1.1 Background

1.2 Smartpole™- Multifunctions & Shared Services Street Pole

1.3 Who Needs to Read the Smartpole™ Product Manual (5 Parts)?

1.4 Purpose of the Smartpole™ Product Manual (5 Parts)

Part 1- System Overview Manual

Part 2- Structural Certification Manual

Part 3- Factory Assembly Manual

Part 4- Installation Manual

Part 5- Specification Drawings Manual

1.5 General Guide to the Smartpole™ Electrical Services

2.0 Pole Hierarchy

2.1 Pole Hierarchy Without Traffic Signals

2.2 Pole Hierarchy With Traffic Signals

3.0 Accessories

3.1 Application of Functions and Accessories

3.2 Standard Light and Outreach Specifications

4.0 Typical Pole Configurations

4.1 Type A Pole

4.1.1 Twin Streetlight Shared Corner Pole

4.1.2 Single Streetlight Shared Corner Pole

4.1.3 Twin Streetlight Mid Block Pole

4.1.4 Single Streetlight Mid Block Pole

4.2 Type Ab Pole

4.2.1 Shared Street Corner Pole

4.2.2 Mid Block Pole

4.3 Type B Pole

4.3.1 Shared Street Corner Pole

4.3.2 Mid Block Pole

4.4 Type C Pole

4.4.1 Shared Street Corner Pole

4.4.2 Double Plaza Lights in Pedestrian Area

4.5 Type D Pole

4.5.1 Shared Street Corner Pole

1.0 INTRODUCTION

WARNING :

The set of documents that comprise the Smartpole™ Product Manual provides information that is appropriate for the application of the Smartpole™ within the central business district of the City of Sydney. However, for any other particular locality, city, state or country, the local standards and regulations imposed by the various relevant authorities must be consulted.

This warning also applies to the application of the Smartpole™ within any wind terrain category greater than that for which this set of documentation has certified.

1.1 Background

As host of the 2000 Olympic and Paralympic Games, the City of Sydney undertook a substantial capital works program to upgrade its street lighting and pedestrian pathways. To assist these objectives, the City commissioned the design and development of a new system of multifunction street poles. This system of poles, is now known as the Smartpole™.

This system is substantially detailed within the Smartpole™ Product Manual - Parts 1 to 5. Copyright in these documents rests with Streetscape Projects.

More than 1,000 new Smartpoles™ were installed at various locations throughout the Sydney CBD. They are designed to play an important but unobtrusive role by improving the urban environment with less street clutter, more effective street signs and brighter, safer streets. The Smartpoles™ clean, simple architectural design, presents a contemporary aesthetic complimentary to a modern cityscape, and assists to distinguish the CBD from the rest of the city.

Smartpoles™ minimise the number of street poles necessary throughout the city. A single Smartpole™ can replace up to six ordinary street poles by incorporating streetlights, traffic signals, traffic and pedestrian signage, promotional banners, real-time electronic message boards, closed-circuit security television, traffic flow cameras and telecommunications equipment.

Smartpoles™ range between five and 12 meters in height and include a designed range of structural capacities. They are deployed depending on traffic and pedestrian volumes, the width and importance of the street, and any specific large structural requirement.

The pole's diameter has been kept to a minimum to reduce visual impact, with easy access for servicing and maintenance via secure hatch covers. At street level, fluted metal casing around the lower section of the pole is designed to discourage billposting and graffiti.

International lighting consultants contributed to the Smartpole™ design with the specification of efficient luminaries and lamps, and refinement of the reflector design. This has provided improved lighting quality, significantly reduced waste upward light, higher energy efficiencies, and diminished glare. House-side shields are also being refined for reduced glare to adjacent residential apartments.

The design excellence of the Smartpole™ has been acknowledged with an Australian Design Award™ in 1998 and was described by judges as: "a good transfer of existing technology, minimising street fixtures whilst providing continuity and improving the urban environment." Later the Smartpole™ also won a Chicago Athenaeum GOOD DESIGN Award® in 1999.

1.2 Smartpole™ - Multifunctions & Shared Services Street Pole

The Smartpole™ is a shared services streetpole designed to reduce the number of streetpoles in the city. The Smartpole™ provides a uniform and consistent system for the attachment of pole accessories. The parties whose services are incorporated in the Smartpole™ are -

- The Roads & Traffic Authority
- the local energy authority
- a number of mobile cellular communications network providers
- City of Installation
- Special Events Technicians

1.3 Who needs to read the Smartpole™ Product Manual (5 Parts)?

All parties responsible for assembling, installing and servicing the Smartpole™ its accessories and any other approved attachments.

These parties currently include the following & their approved sub-contractors:

- The Roads & Traffic Authority
- the local energy authority
- mobile cellular communications network providers & their sub-contractors
- City of Installation
- Special Events Technicians

1.4 Purpose of the Smartpole™ Product Manual (5 Parts)

The Product Manual consists of 5 parts

- Part 1- System Overview Manual
- Part 2- Structural Certification Manual
- Part 3- Factory Assembly Manual
- Part 4- Installation Manual
- Part 5- Specification Drawings Manual

Part 1- System Overview Manual

To provide relevant parties with an overview of the Smartpole™ system. The manual details the Smartpole™ hierachy, what Smartpole™ accessories are suitable for each pole, and illustrates typical pole configurations.

Part 2- Structural Certification Manual.

There is a wide range of accessories that can be attached to each Smartpole™ type. Their application must be carefully controlled and constrained to within the parameters specified in the Structural Certification Manual. The specified maximum loading limitations must not be exceeded.

The addition of any accessory onto a Smartpole™ requires the certification from a qualified practising structural engineer that the particular Smartpole™ and its foundation is capable of supporting the resultant loadings. This certification must also take into account:

- the proposed attachment method
- any attachments already located on that particular Smartpole™
- any adjacent excavations or building works that could reduce the stability
- the relevant wind terrain category

Part 3- Factory Assembly Manual

The methods and procedures described in the Factory Assembly Manual are indicative only. The manufacturer/s must make their own determination as to the suitability of the suggested assembly methods.

The Factory Assembly Manual provides the relevant parties with step by step procedures for assembling the Smartpole™ and its accessories in the factory. For each pole type and its accessories, the following information is given;

- A list of tasks to be carried out in chronological order, required to assemble the pole type and its accessories in the factory.
- Specific instructions relative to each task.
- A list of parts and quantity required for each assembly.
- A list of fasteners required for each assembly
- A technical drawing reference number for each part.
- Exploded view drawings detail the parts making up each assembly.

Note : The uniform look and integrity of the Smartpoles™ must be maintained.

Part 4- Installation Manual

The methods and procedures described in the Installation Manual are indicative only. The installer/s must make their own determination as to the suitability of the suggested installation methods, particularly having regard to latent site conditions and the requirements of relevant public authorities.

The Installation Manual provides the relevant parties with step by step procedure for installing each pole type and its accessories on site. For each pole type and its accessories, the following information is given;

- A list of tasks to be carried out in chronological order, required to install each pole type and its accessories.
- Specific instructions relative to each task.
- A list of parts and quantity required for each pole type and its accessories.
- A list of fasteners required for each pole type and its accessories.
- A technical drawing reference number for each part.
- Exploded view drawings detail the parts making up that assembly.

Note : The uniform look and integrity of the Smartpoles™ must be maintained.

Part 5- Specification Drawing Manual

This is an A3 reduced scale set of drawings for 'desk reference' only - they are not to be used for production. [The same drawing set is available as Full Size Drawings for the purpose of production] Included in the drawing set are all pole type assemblies, accessory assemblies and part drawings.

1.5 General Guide to the Smartpole™ Electrical Services

Within the City of Installation's local government area, where multi electrical functions are required, the Smartpoles™ have been installed with an intermix of electricity supply sources. The large majority being single insulated & earthed via a newly installed 5-core cable, with:

- 3 phase supply, servicing lighting and other pole attachments :
- 2 phases switched for street lighting and other lighting.
- 1 phase un-switched for pole attachments such as CCTV, electronic signboards, microcell telecommunications equipment
- Supply to RTA signals from a separate special small service.

A minority of the Smartpoles™ are double insulated & unearthed. These may have single, two or three phase supply cables servicing lighting functions, as well as:

- Un-switched supply, to microcell telecommunications equipment mounted on the Smartpole™, from a separate special small service.
- Supply to RTA signals from another separate special small service.

With any intermix of electrical supply sources it is of utmost importance that the local electrical authority requirements are strictly adhered to. These are outlined in the Smartpole™ Product Manual - Part 4, Installation Manual, item

1.6 Electrical Limitations.

The local electrical authority must be consulted for their requirements for any new Smartpole™ installations or additions or extensions to any existing network of Smartpoles™.

Access to the Smartpole™ electrical compartments is strictly limited to those personnel authorised by the local electrical authority.

2.0 POLE HIERARCHY

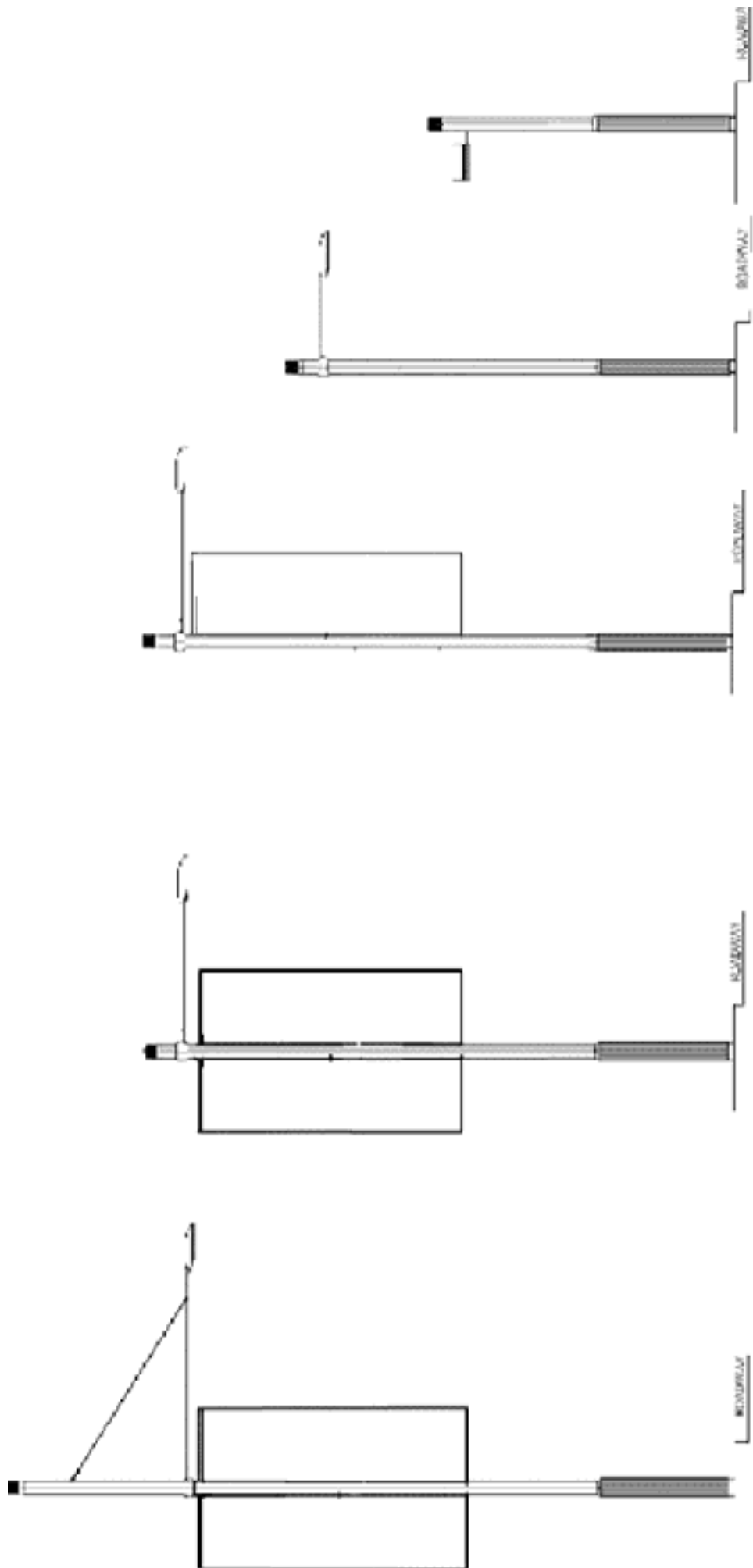

Type D

Type C

Type B

Type Ab

Type A

2.1 POLE HIERACHY WITHOUT TRAFFIC SIGNALS

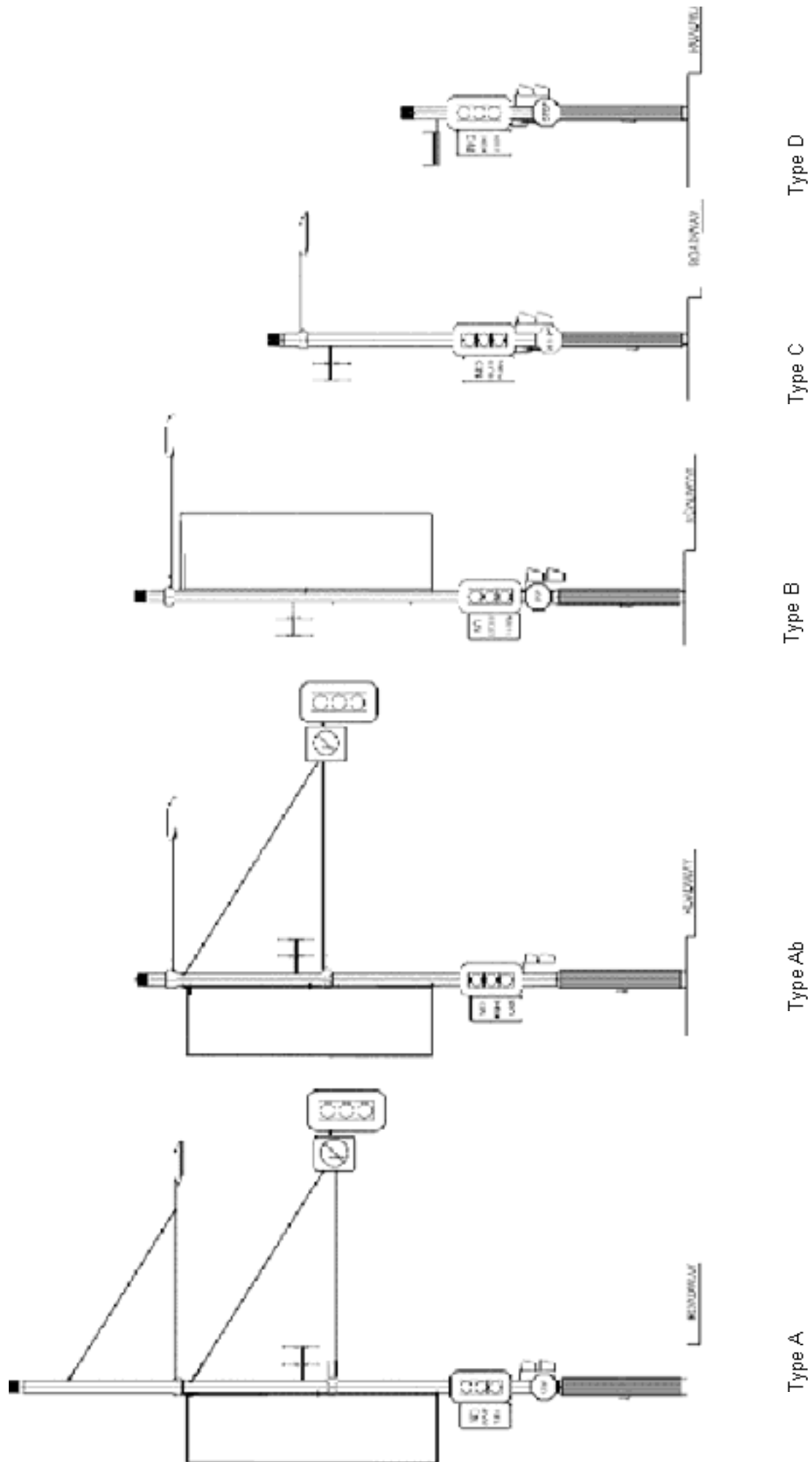

2.2 POLE HIERACHY WITH TRAFFIC SIGNALS

3.0 ACCESSORIES

3.1 APPLICATION OF FUNCTIONS & ACCESSORIES

SMARTPOLE™ TYPES	A	Ab	B	C	D
Overall Height (m)	12	9.6	9.6	7.2	4.8
Internal Structural Steel Height (m)	8.6	8.6	3.2	3.2	3.2
Base diameter (mm)	300	300	250	250	250

LIGHTING ACCESSORIES

4M TWIN OUTREACH	<input checked="" type="checkbox"/>	<input type="checkbox"/>	<input type="checkbox"/>	<input type="checkbox"/>	<input type="checkbox"/>
4M SINGLE OUTREACH	<input checked="" type="checkbox"/>	<input type="checkbox"/>	<input type="checkbox"/>	<input type="checkbox"/>	<input type="checkbox"/>
3M SINGLE OUTREACH	<input type="checkbox"/>	<input checked="" type="checkbox"/>	<input checked="" type="checkbox"/>	<input type="checkbox"/>	<input type="checkbox"/>
2M SINGLE OUTREACH	<input type="checkbox"/>	<input checked="" type="checkbox"/>	<input checked="" type="checkbox"/>	<input checked="" type="checkbox"/>	<input type="checkbox"/>
PLAZA LUMINAIRE	<input type="checkbox"/>	<input checked="" type="checkbox"/>	<input checked="" type="checkbox"/>	<input checked="" type="checkbox"/>	<input type="checkbox"/>
FOOTPATH LUMINAIRE	<input checked="" type="checkbox"/>	<input checked="" type="checkbox"/>	<input checked="" type="checkbox"/>	<input checked="" type="checkbox"/>	<input checked="" type="checkbox"/>
FLOOD / SPOT LIGHTS	<input checked="" type="checkbox"/>	<input checked="" type="checkbox"/>	<input checked="" type="checkbox"/>	<input checked="" type="checkbox"/>	<input type="checkbox"/>

RTA ACCESSORIES

TRAFFIC SIGNALS ON OUTREACH ARM *	<input checked="" type="checkbox"/>	<input checked="" type="checkbox"/>	<input type="checkbox"/>	<input type="checkbox"/>	<input type="checkbox"/>
TRAFFIC SIGNALS ATTACHED TO COLUMN	<input checked="" type="checkbox"/>	<input checked="" type="checkbox"/>	<input checked="" type="checkbox"/>	<input checked="" type="checkbox"/>	<input checked="" type="checkbox"/>
PEDESTRIAN WALK SIGNALS	<input checked="" type="checkbox"/>	<input checked="" type="checkbox"/>	<input checked="" type="checkbox"/>	<input checked="" type="checkbox"/>	<input checked="" type="checkbox"/>
PEDESTRIAN PUSH BUTTON	<input checked="" type="checkbox"/>	<input checked="" type="checkbox"/>	<input checked="" type="checkbox"/>	<input checked="" type="checkbox"/>	<input checked="" type="checkbox"/>
AUDIO TACTILE UNIT	<input checked="" type="checkbox"/>	<input checked="" type="checkbox"/>	<input checked="" type="checkbox"/>	<input checked="" type="checkbox"/>	<input checked="" type="checkbox"/>

OTHER ACCESSORIES

1 BANNER *	<input checked="" type="checkbox"/>	<input checked="" type="checkbox"/>	<input checked="" type="checkbox"/>	<input type="checkbox"/>	<input type="checkbox"/>
2 BANNERS *	<input checked="" type="checkbox"/>	<input checked="" type="checkbox"/>	<input type="checkbox"/>	<input type="checkbox"/>	<input type="checkbox"/>
TELECOMMUNICATIONS AERIAL	<input checked="" type="checkbox"/>	<input checked="" type="checkbox"/>	<input checked="" type="checkbox"/>	<input checked="" type="checkbox"/>	<input type="checkbox"/>
STREET NAME SIGN	<input checked="" type="checkbox"/>	<input checked="" type="checkbox"/>	<input checked="" type="checkbox"/>	<input checked="" type="checkbox"/>	<input checked="" type="checkbox"/>
KERBSIDE/PARKING RESTRICTION SIGNAGE	<input checked="" type="checkbox"/>	<input checked="" type="checkbox"/>	<input checked="" type="checkbox"/>	<input checked="" type="checkbox"/>	<input checked="" type="checkbox"/>
PEDESTRIAN ADVISORY & DIRECTIONAL SIGNAGE *	<input checked="" type="checkbox"/>	<input checked="" type="checkbox"/>	<input checked="" type="checkbox"/>	<input checked="" type="checkbox"/>	<input checked="" type="checkbox"/>
TRAFFIC ADVISORY & DIRECTIONAL SIGNAGE *	<input checked="" type="checkbox"/>	<input checked="" type="checkbox"/>	<input checked="" type="checkbox"/>	<input checked="" type="checkbox"/>	<input checked="" type="checkbox"/>
CLOSED CIRCUIT TELEVISION (CCTV) CAMERAS	<input checked="" type="checkbox"/>	<input checked="" type="checkbox"/>	<input checked="" type="checkbox"/>	<input checked="" type="checkbox"/>	<input checked="" type="checkbox"/>
LARGE ELECTRONIC MESSAGING BOARDS (SMARTSIGN) *	<input checked="" type="checkbox"/>	<input checked="" type="checkbox"/>	<input type="checkbox"/>	<input type="checkbox"/>	<input type="checkbox"/>

Pole type **MAY** accommodate accessory

Pole **WILL NOT**, or is not intended to accommodate accessory

* Refer to Structural Certification (Part 2 of Product Manual) for limitations.

3.2 Standard Light & Outreach Specifications

ROADWAY LIGHTING								
Unless otherwise agreed to in writing by CoS								
Pole Type	Outreach			Light				Example of use in City of Sydney
	Type	Reference Length (m) Note 1	Reference Height (m) Note 2	Lamp Watts	Reflector	Rexel Aust. Luminaire spec No.	Metal Halide Lamp spec. No.	
A	Twin	4	9	250	Standard	OPN250MHA3CS	MS250/HOR 4000K	George Street
A	Single	4	9	400	Toe-in	OPN400MHA2CS	MS400/HOR/ ED28/ 4000K	Bridge Street
A	Double	4	9	400	Toe-in	OPN400MHA2CS	MS400/HOR/ ED28/ 4000K	Eddy Avenue
Ab	Single	3	9	400	Toe-in	OPN400MHA2CS	MS400/HOR/ ED28/ 4000K	Park Street
B	Single	3	9	400	Toe-in	OPN400MHA2CS	MS400/HOR/ ED28/ 4000K	York Street
C	Single	2	6.6	250	Standard	OPN250MHA3CS	MS250/HOR 4000K	Barlow Street

FOOTPATH LIGHTING								
Unless otherwise agreed to in writing by CoS								
Pole Type	Outreach			Light				Example of use in City of Sydney
	Type	Reference Length (m) Note 1	Reference Height (m) Note 2	Lamp Watts	Reflector	KIM Luminaire spec No.	Metal Halide Lamp spec. No.	
D	Kim 200mm	0.6	4.3	70	Type 2	CC217A200/70W CDMT/CoS/DIPGLS	CDMT 70W 3000K	Druitt Street (cnr George St)

PLAZA AREA LIGHTING (Refer Note 3)								
Unless otherwise agreed to writing by CoS								
Pole Type	Outreach			Light				Example of use in City of Sydney
	Type	Reference Length (m) Note 1	Reference Height (m) Note 2	Lamp Watts	Reflector	THORN Luminaire spec No.	Metal Halide Lamp spec. No.	
AB	Double	0.8	9	150	Custom	Lemnis 150MH	CDMT150W 3000K	Customs House Square
B	Double	0.8	9	250	Standard	Lemnis 250MH	MH250/HOR 3200K	Martin Place
C	Double	0.8	6.6	150	Custom	Lemnis 150MH	CDMT 150W 3000K	Alfred Street Plaza

Note 1 : Outreach reference length = Centre of pole to nominal centre of lamp

Note 2 : Outreach reference height = nominal paving level to centre of outreach

Note 3 : Final reflector/luminaire specification is dependant upon lighting/site geometry

4.0 TYPICAL POLE CONFIGURATIONS

4.1 Type A Pole

4.1.1 Twin Streetlight Shared Corner Pole

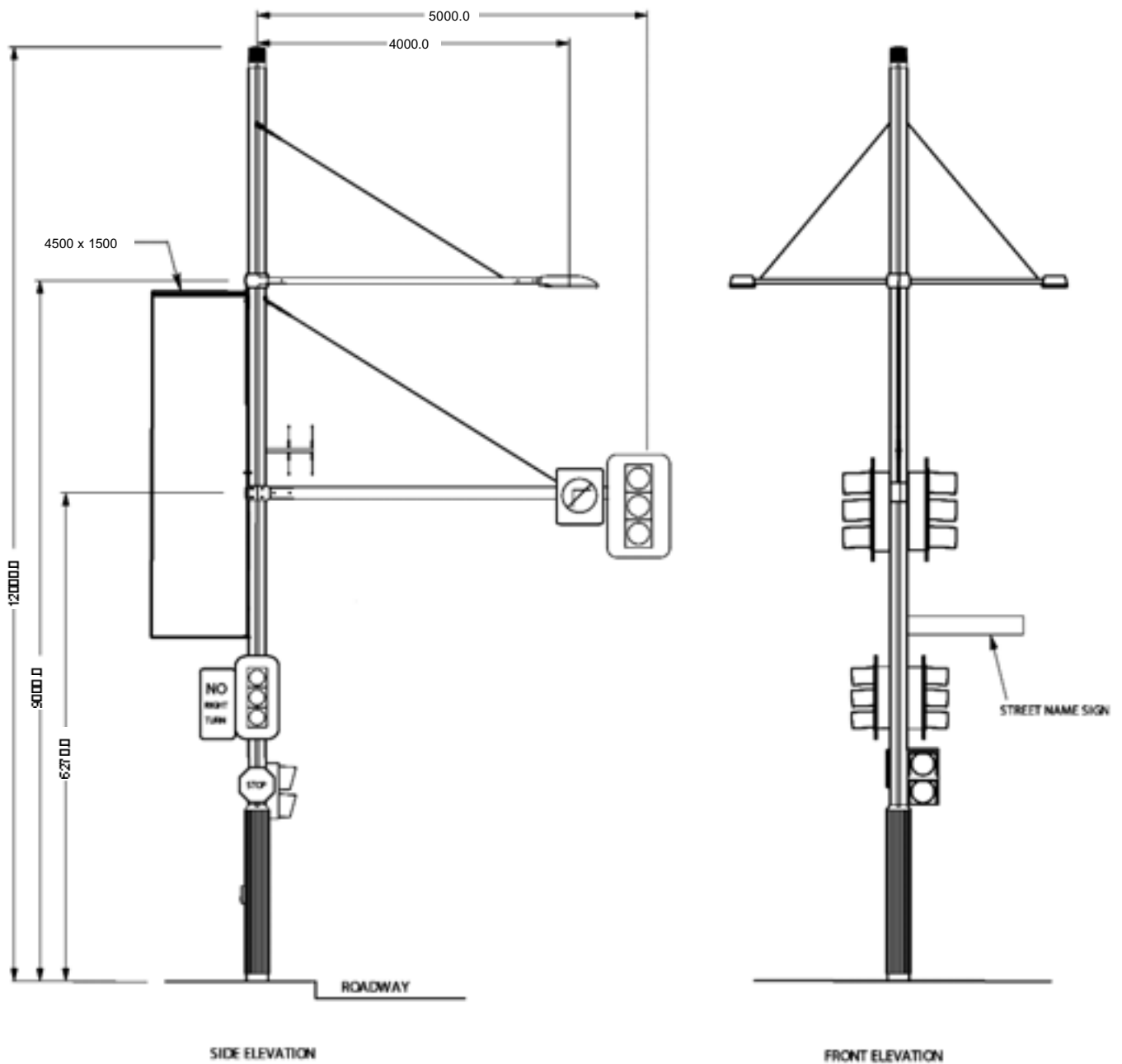

Smartpole Type A with Twin Street Lights. Example of use as a shared street corner pole.

4.1.2 Single Streetlight Shared Corner Pole

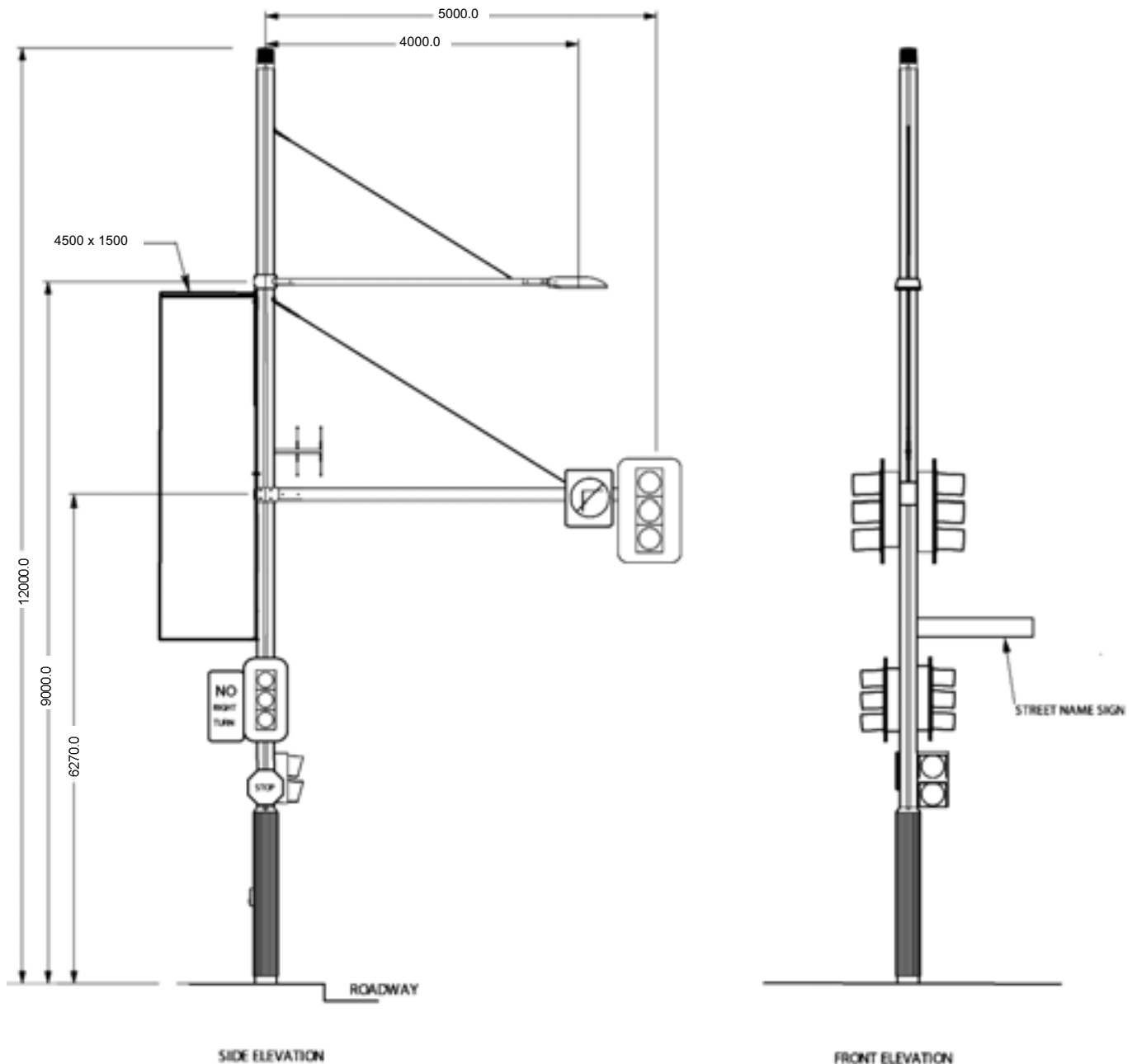

Smartpole Type A with single street light. Example of use as a shared street corner pole.

4.1.3 Twin Streetlight Mid Block Pole

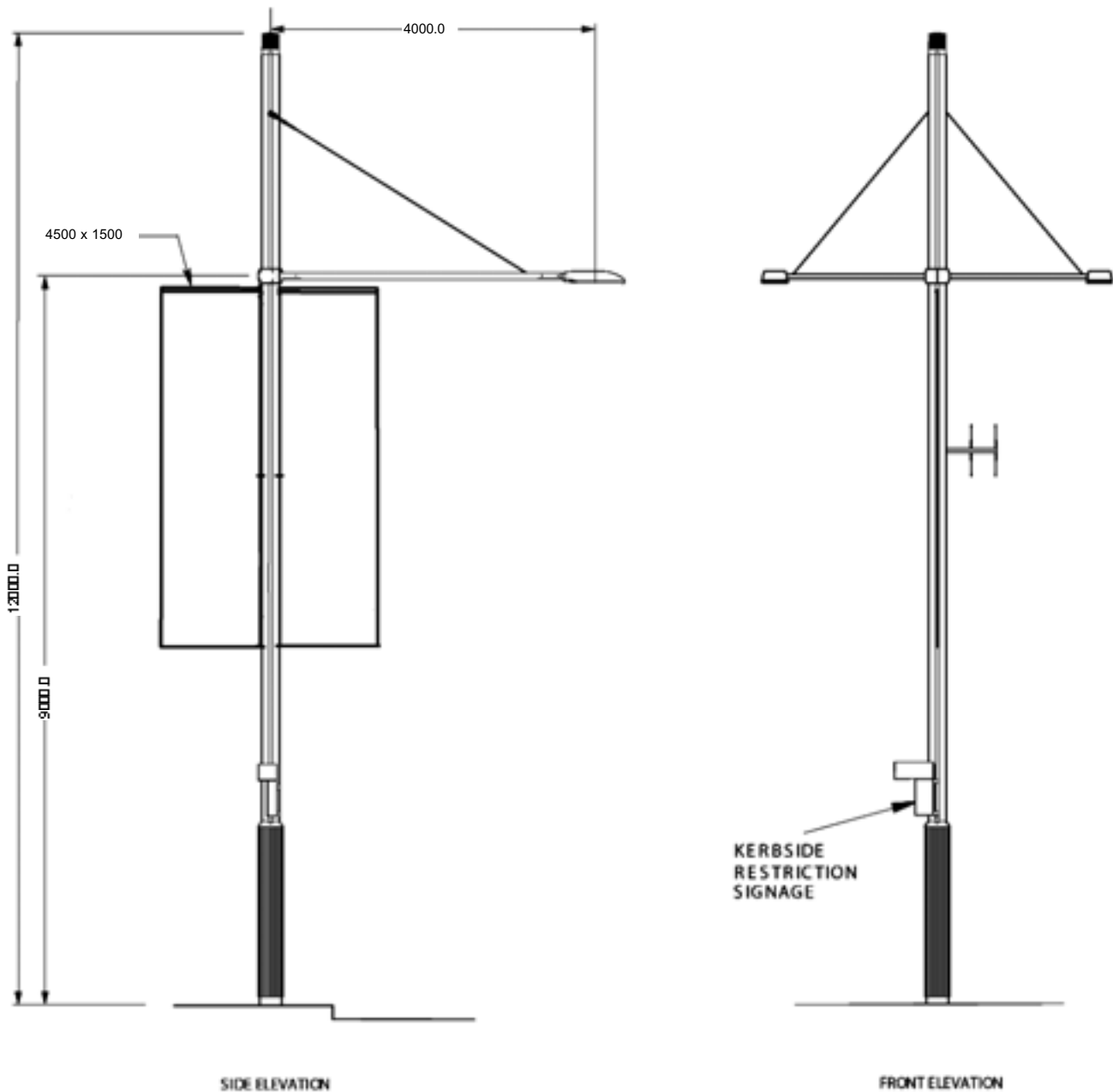

Smartpole Type A with Twin Street Lights. Example of use as a mid-street block pole.

4.1.4 Single Streetlight Mid Block Pole

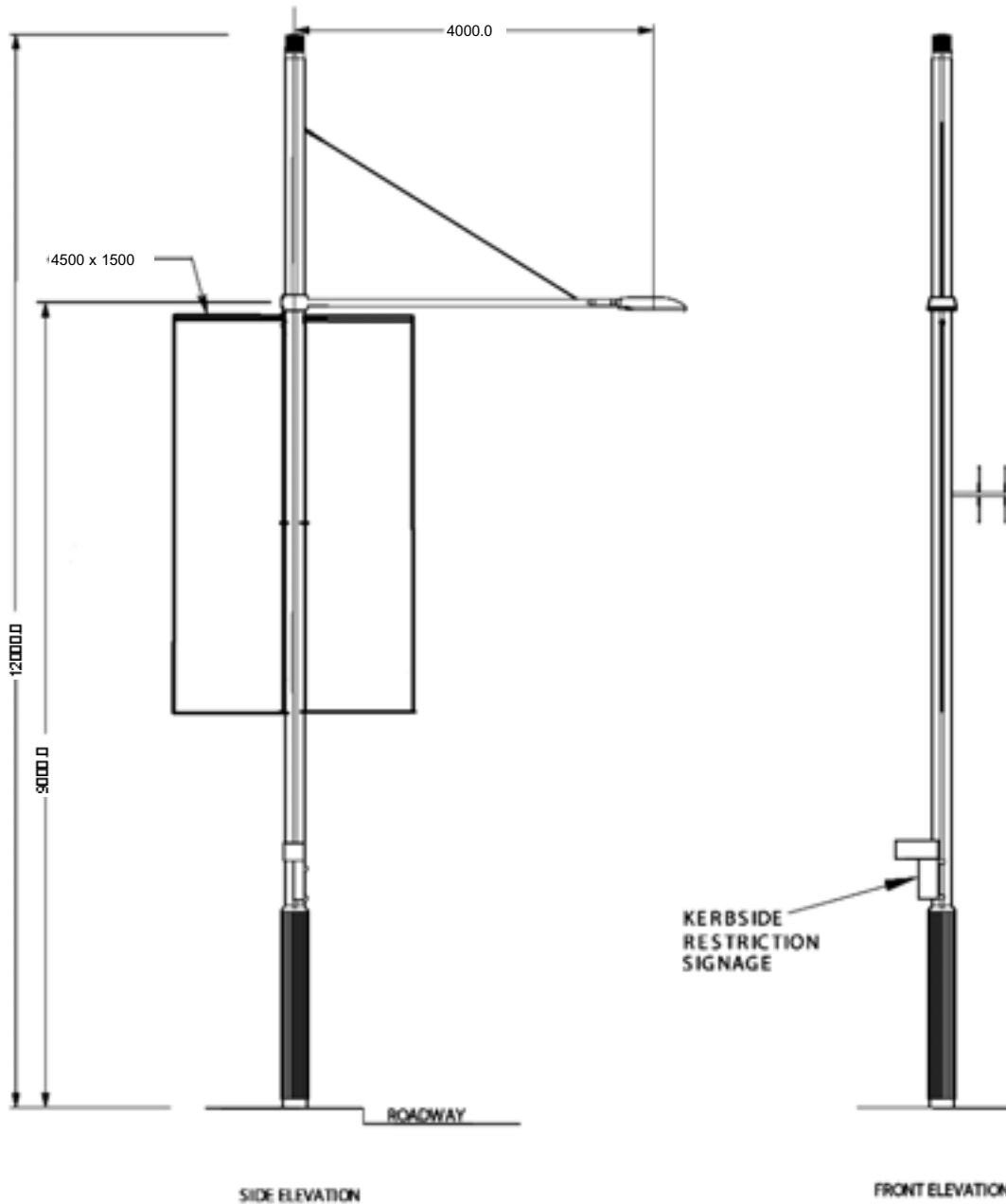

Smartpole Type A with single street light. Example of use as a mid street block pole.

4.2 Type Ab Pole

4.2.1 Shared Street Corner Pole

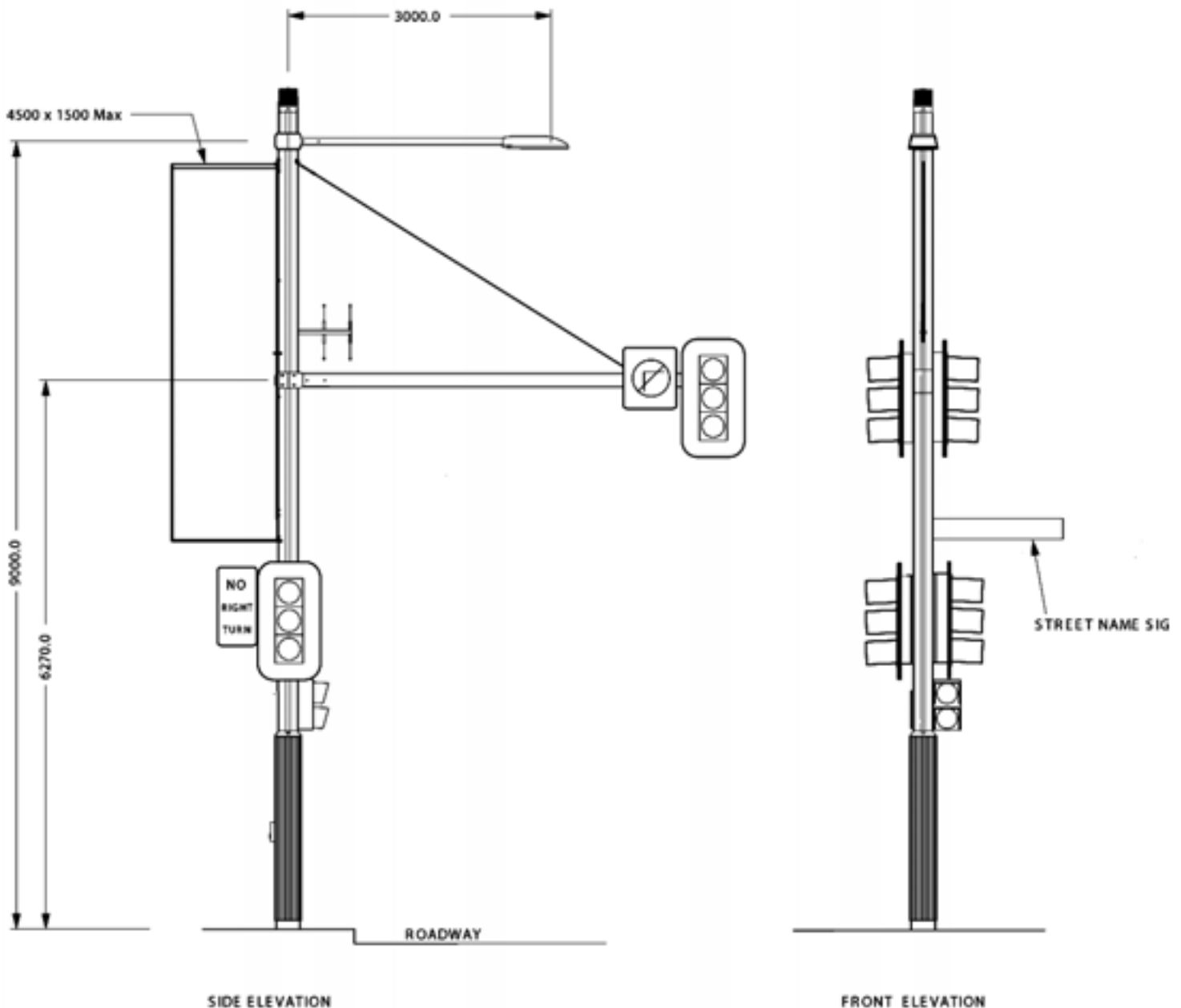

Smartpole Type Ab. Example of use as a shared street corner pole.

4.2.2 Mid Block Pole

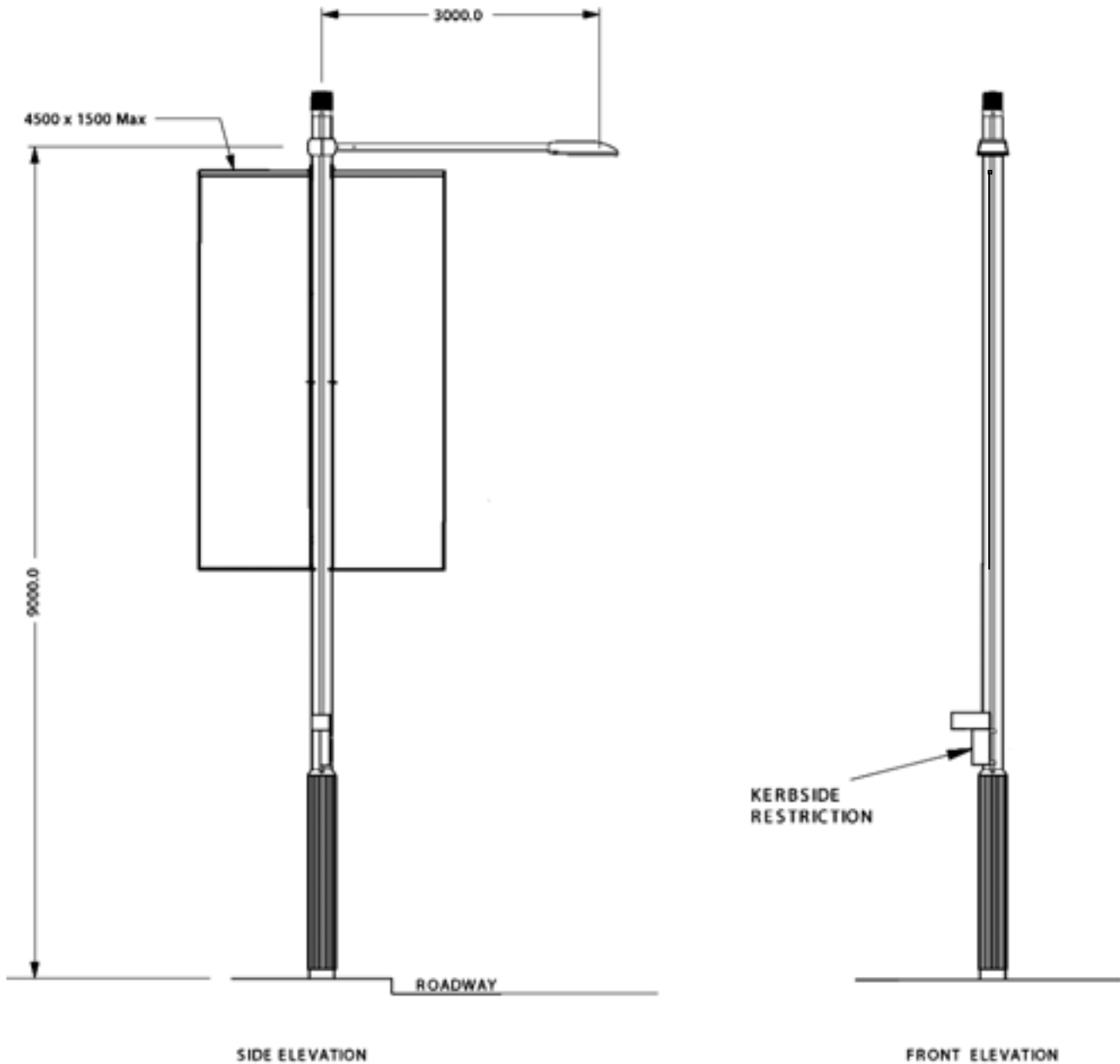

Smartpole Type Ab. Example of use as a mid street block pole.

4.3 Type B Pole

4.3.1 Shared Street Corner Pole

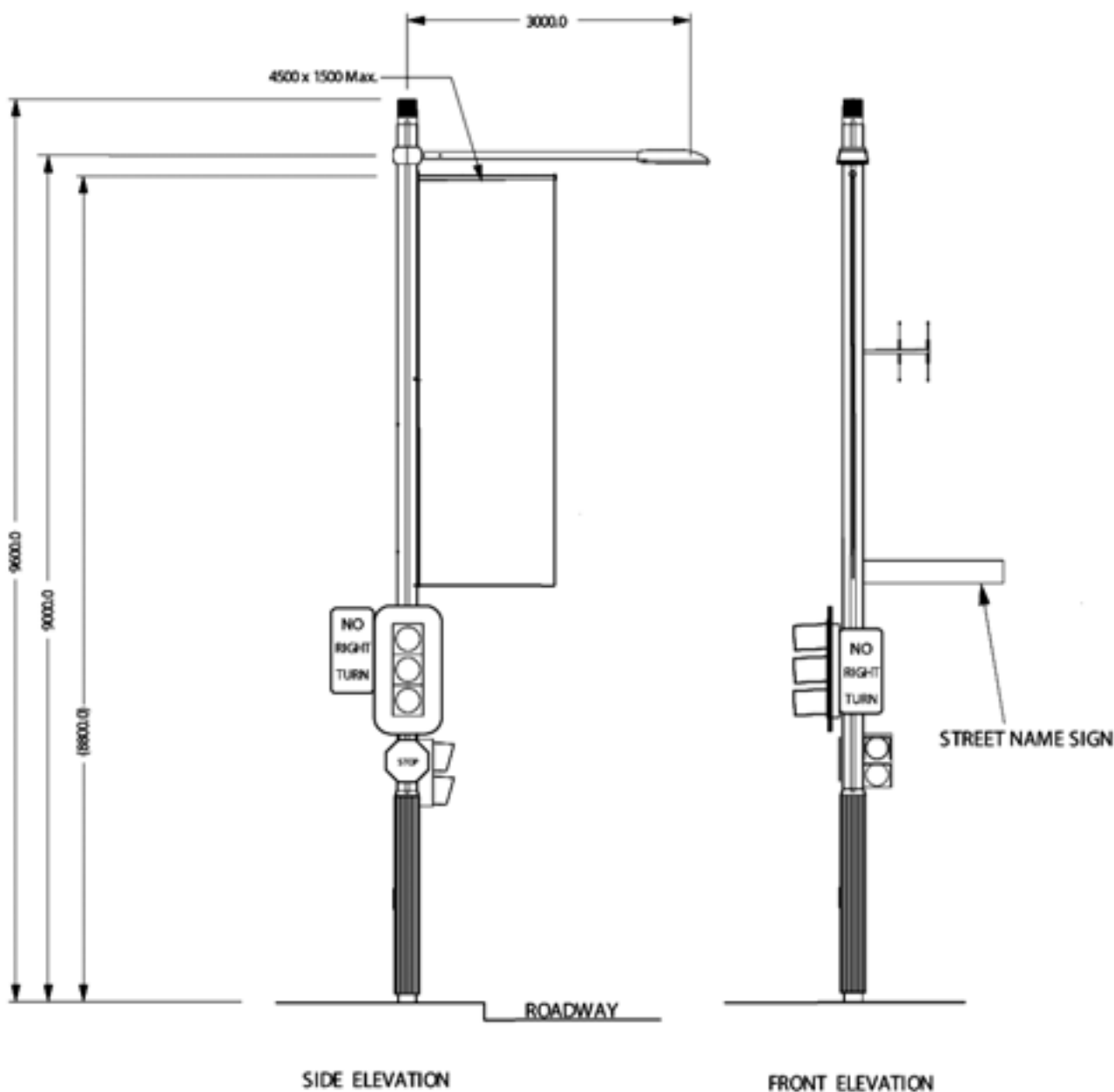

Smartpole Type B. Example of use as a shared corner pole.

4.3.2 Mid Block Pole

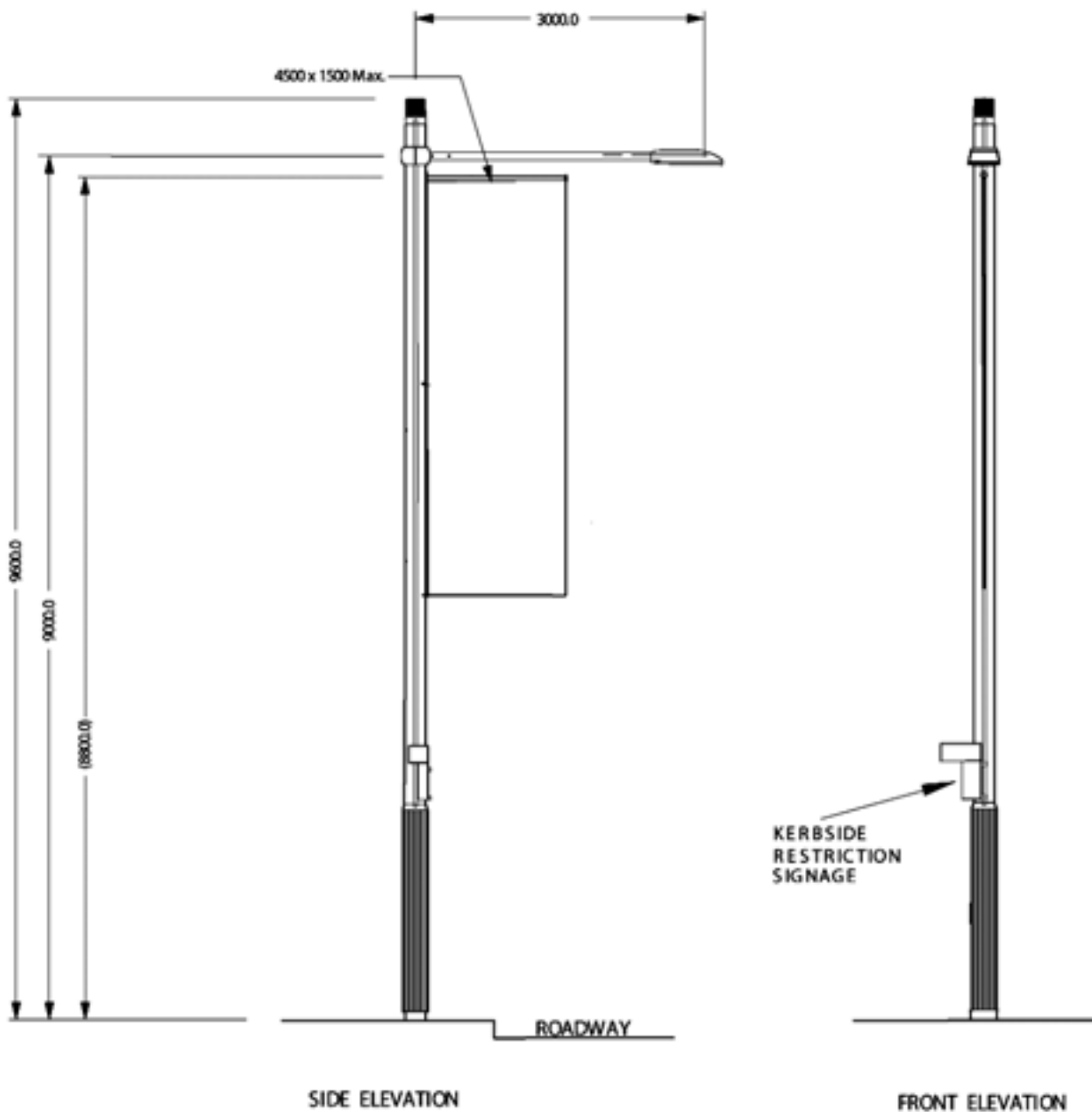

Smartpole Type B. Example of use as a mid street block pole.

4.4 Type C Pole

4.4.1 Shared Street Corner Pole

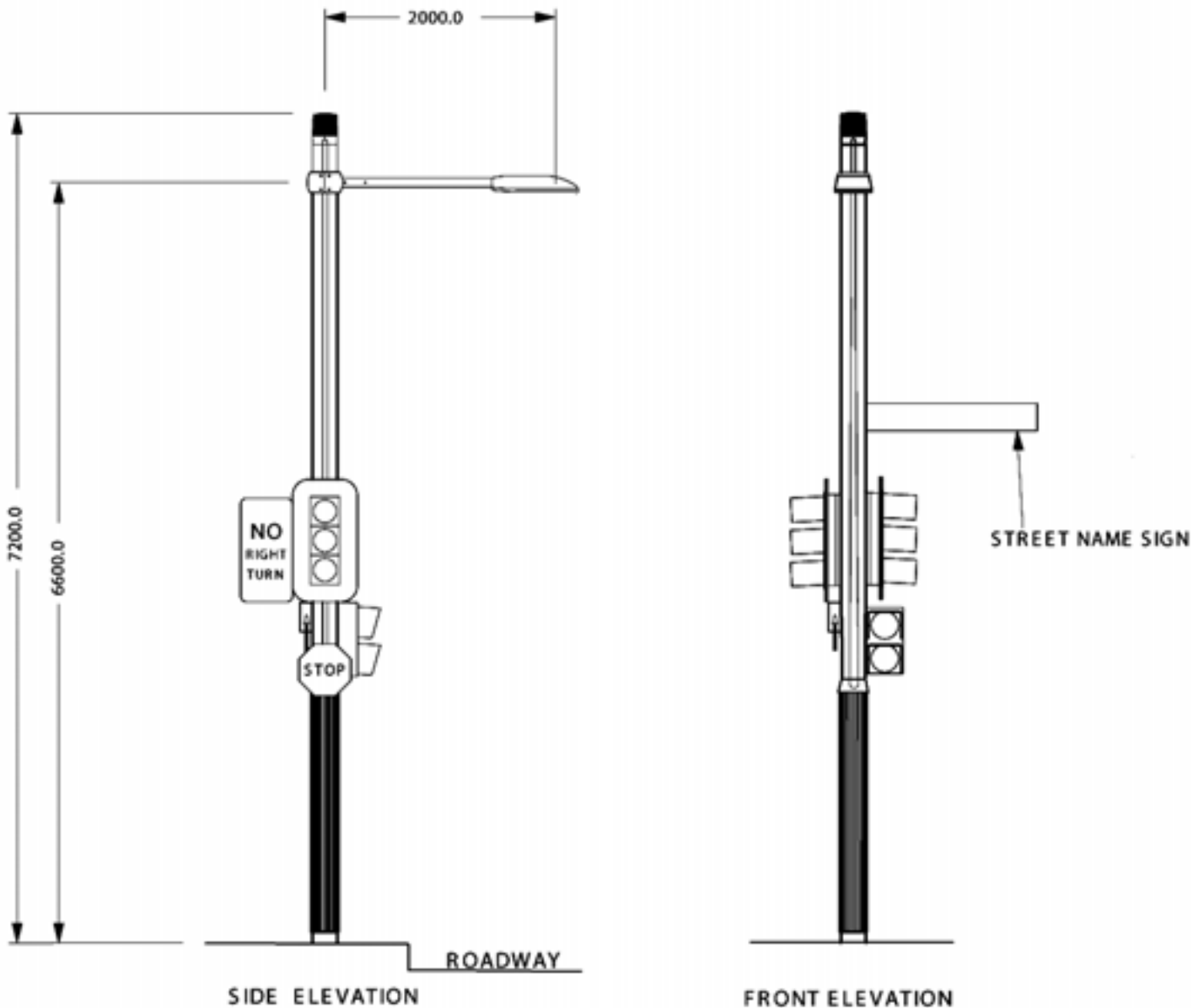

Smartpole Type C. Example of use as a shared street corner pole.

4.4.2 Double Plaza Lights in Pedestrian Area

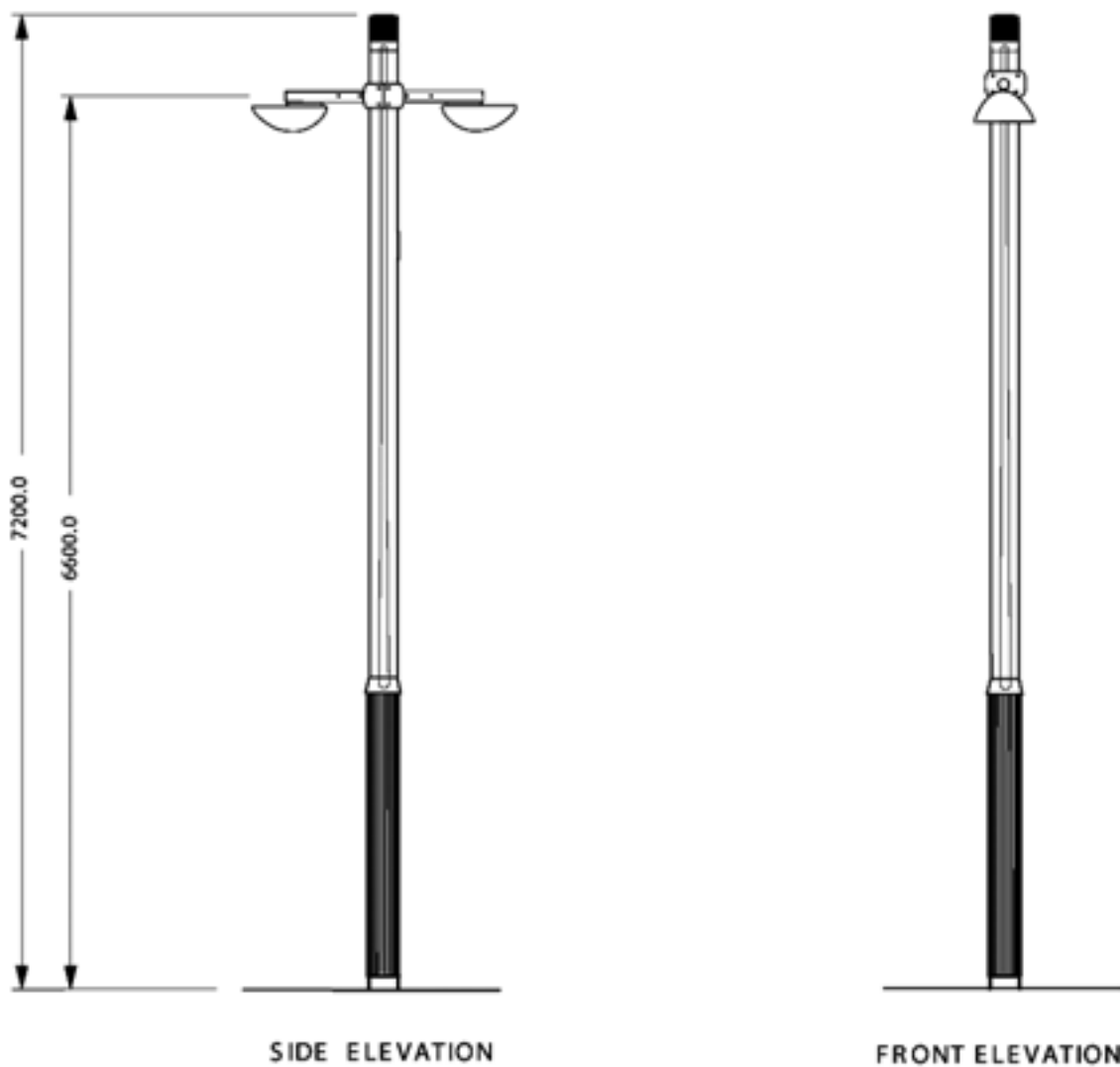

Smartpole Type C with double Plaza Lights. Example of use in pedestrian plaza area.

4.5 Type D Pole

4.5.1 Shared Street Corner Pole

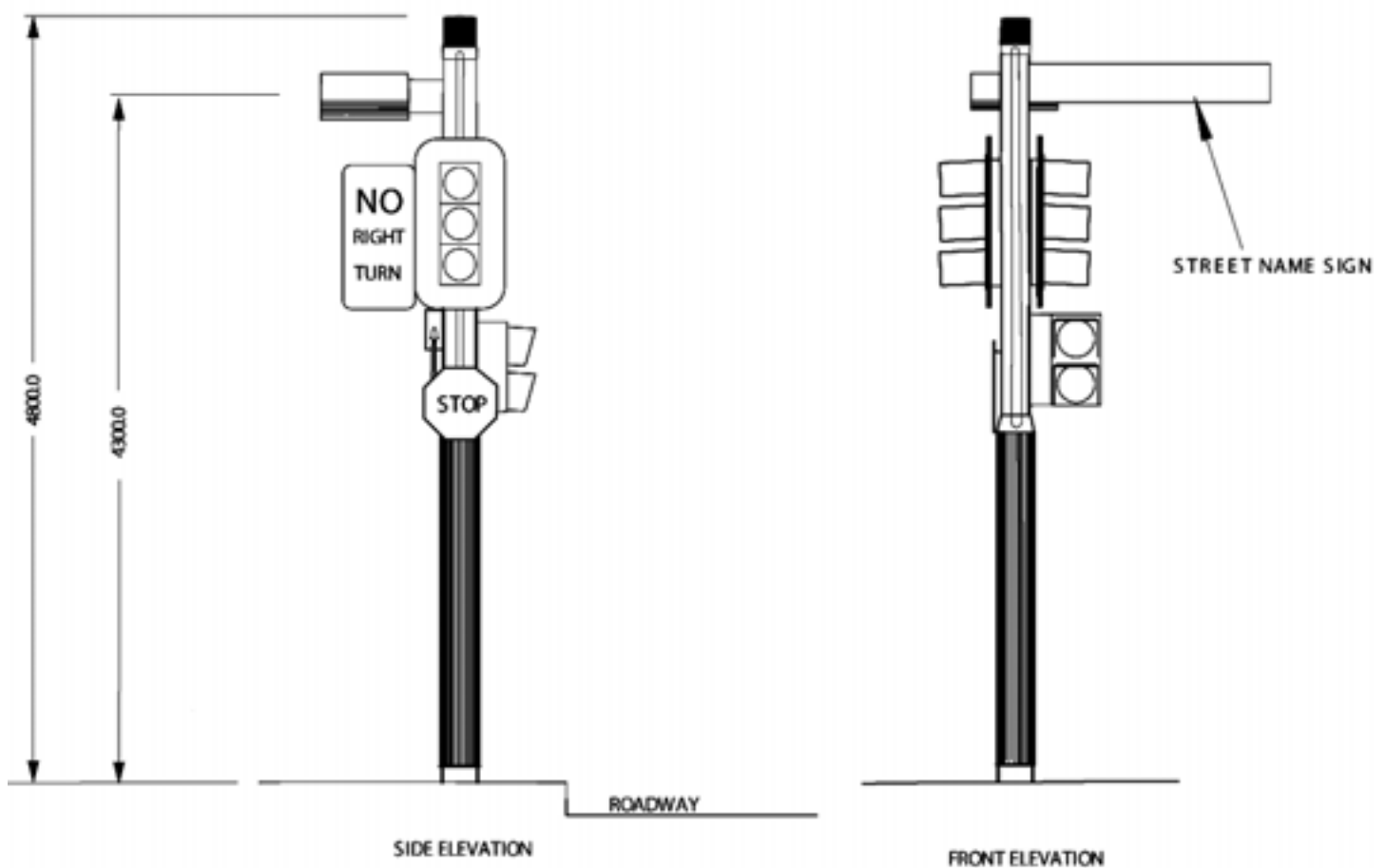

Smartpole Type D. Example of use as a shared street corner pole.

Appendices: Smartpole™ Strategy and Approved Luminaires

A.4

Approved Luminaires

A specially developed range of streetlighting luminaires, based on the Rexell GEC Optispan Aeroscreen cut-off unit, are approved for the specific traffic route lighting applications necessary in the City of Sydney.

These luminaires meet the City of Sydney's requirements for specific installation arrangements on Smartpoles™ and are designed to form a component of the new suite of street furniture. These cut-off luminaires are designed to utilise reduced envelope (either ED28 or BT28) dedicated horizontal burning metal halide lamps.

If any upgrade situation requires a luminaire with semi cut-off distribution to meet the relevant Standards, this is to be Rexell GEC Optispan semi cut-off, utilising the same lamps and control gear as the cut-off execution in order to simplify maintenance arrangements.

Luminaires for other applications, such as pedestrian plazas and footpaths, already employed in the City, include the Thorn Lemnis, Kim Curvilinear, the SLI "Macquarie" and the Bega 8081. All future versions of these luminaires or similar types are to meet the photometric requirements of the Australian Standard AS/NZS1158 3.1: 1999 Pedestrian Area (Category P) Lighting, together with specified test reports. Variations to the standard range of streetlighting luminaires are required to be submitted to the Director, City Projects, for approval prior to installation in the public realm.

All luminaires are to be equipped with lamps as described in earlier sections of this Strategy document.