

Legible Sydney - Volume 2 Design Manual



REVISION REGISTER

Revision	Author	Date	Amendments
A–K	Minale Tattersfield	07.03.2014	Final revision whole document
L	Full Extent	10.10.2014	Revision of map section
M	City of Sydney	January 2015	Revision of Pylon, Flag and Finger and Tacilte Indicator sections, Taxi signage and graphic grids added
N	City of Sydney	September 2015	Revision of Pylon, Flag and Finger sign and Map sections
O	City of Sydney	March 2016	Revision of Placement and Messaging section
P	City of Sydney	June 2019	Update of graphic application specification for pylon panels

Contributing Consultants

Minale Tattersfield

Full Extent

Tzannes Architects

Best Group

A to B Wayfinding

Introduction	1	Finger Sign - Graphic Grid	30	Messaging Guidelines - Messaging Hierarchy.....	58
Sign Family.....	2	Flag Sign - Public Transport	31	Messaging Guidelines - Additional Information.....	59
Graphic Specifications For all Signtypes of Legible Sydney.....	5	Flag Sign - Public Transport - Graphic Grid.....	32	Documentation	60
Pylon Sign	6	Wayfinding Map.....	33	Tactile/Braille Signage	61
Pylon Components.....	7	Mapping Features	34	Tactile/Braille Signage - Placement	62
Pylon Elevations.....	9	Map Production Process.....	35	Tactile/Braille Signage - Graphic Insert.....	63
Pylon Assembly Drawing.....	10	Typical Map Crop Examples.....	36	Tactile/Braille Signage - Pilot Photos	64
Construction Specifications	11	Line Specifications & Scale	37	Audio Tactile Button & Existing Rubber Tactile Sign	65
Pylon - Graphic Grid.....	12	Area Specifications.....	38	Typical Tactile/Braille Signage Placement on George Street.....	66
Pylon Small – For Special Locations	17	Text Specifications.....	39	Tactile/Braille Signage - Messaging Rules.....	67
Pylon Small - Graphic Grid.....	19	Pictogram Specifications & Map Grid.....	40	Taxi signage	68
Pylon Surface Mounted – Single Sided.....	20	Walking Circles	41	Taxi Rank Pylon Components & Specifications	69
Pylon Surface Mounted - Graphic Grid.....	21	Placement and Messaging Guidelines	42	Taxi Rank Pylon - Graphics Panel 2.....	70
Map Wall Mounted	22	Placement Guidelines - Desktop Review	44	Taxi Rank Pylon - Graphics Panel 3.....	71
Map wall mounted - Graphic Grid.....	23	Placement Guidelines - Data Collection and Layering	45	Taxi Rank Pylon - Graphics Panel 4.....	72
Map wall mounted small - Graphic Grid.....	24	Placement Guidelines - Filtering.....	46	Taxi Finger Sign.....	73
Flag & Finger Signs	25	Placement Guidelines - Filtering / Viewing Distances.....	47	Appendices	
Flag Sign – Panel Details for Smart Pole Bracket	26	Placement Guidelines - Draft Placement Scheme.....	48	Appendix 1 Wayfinding Signage Pylon and Taxi Rank Pylon - Construction Drawings	
Finger Sign – Panel Details for Smart Pole Bracket	27	Placement Guidelines - On Site Audit.....	49	Appendix 2 Tactile/Braille Signage - Construction Drawings	
Flag & Finger Sign – Panel Details For RMS Pole Bracket.....	28	Placement Guidelines - Clutter Reduction	52	Appendix 3 Wayfinding Destination Schedule	
Flag Sign - Graphic Grid	29	Messaging Guidelines - Place Naming	53		
		Messaging Guidelines - Addressing	56		
		Messaging Guidelines - Directional Information	57		

Purpose of this Manual

This Design Manual has been created to assist with the planning, documentation and tendering of the City of Sydney’s pedestrian wayfinding signage system. It sits alongside the City’s internal document for signage maintenance, which outlines the ongoing management of installed signage covering the physical sign maintenance and ongoing content management of the system.

Using this Manual

The following document provides conventions and specifications on graphics, colours and industrial design as well as guidelines on placement and messaging of wayfinding signage. It is to be used for the design, placement and manufacture and installation of new signage.

The appendix further includes construction drawings for pylon sign, taxi pylon sign, flag and finger signs and Tactile/Braille street signage.

The Wayfinding Destination Schedule is also attached to assist with messaging development (refer to Placement and Messaging Guidelines).

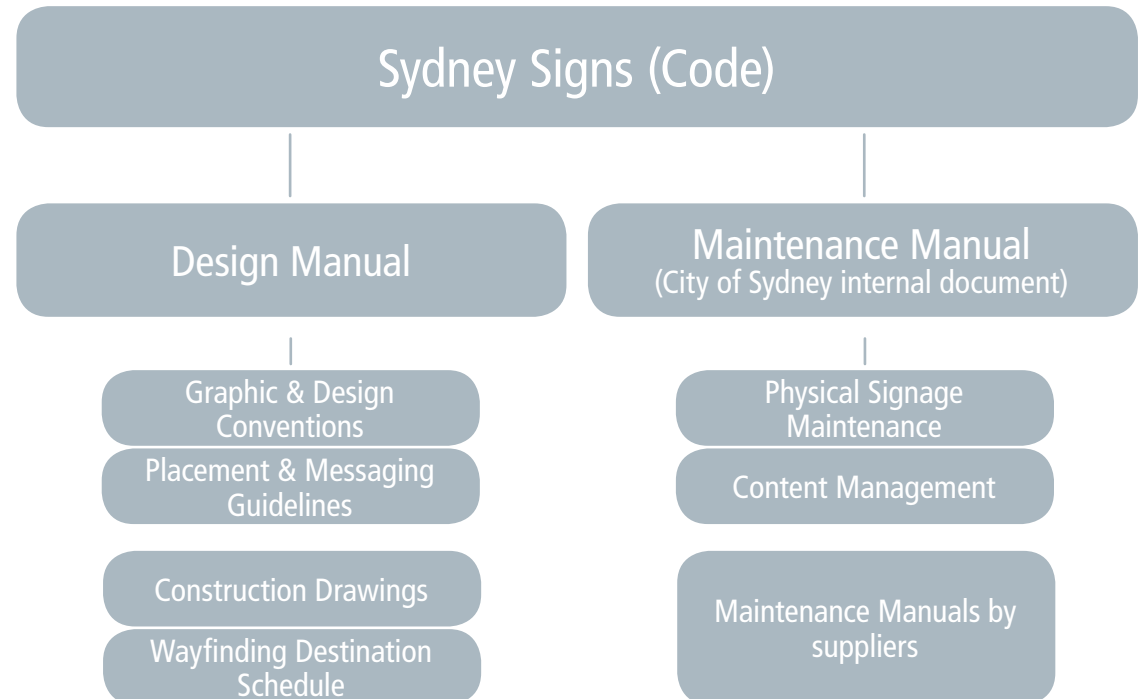



Pylon – Free Standing, Wall Mounted,
Small Free Standing, Taxi Rank, Taxi Stand

Flag & Finger Sign – Fixed to pole: Wayfinding, Public Transport, Taxi
Tactile Indicator

W7.1 Small Map

W7

W8

W9

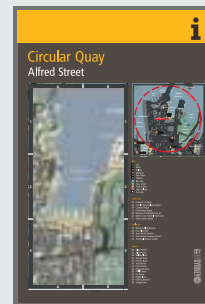
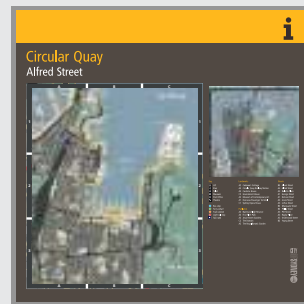

Map – Surface mounted

Destination
Marker

Interpretation
Marker

The Legible Sydney wayfinding signage family comprises various sign types, which cover a number of signage requirements in the urban environment.

Design Development and Consultation

The main 4 signage types (Pylon, Flag, Finger and Tactile/Braille signage) were developed in detail over a period of almost two years and in close consultation with internal and external key stakeholders.

In 2013 a series of mock-ups were prepared for public exhibition and feedback on colours and graphics of the proposed signage, which resulted in further development of the signs.

A pilot was installed in late 2014 to further test the industrial design and installation methods of the signs. Independent evaluation and stakeholder feedback was collated and feedback integrated in the final design and preparation of the construction drawings.

W1 – W3. Pylon – freestanding and surface mounted

The Pylon is used at arrival points near transport hubs, at important nodes, decision points, public places and major destinations. It provides a 'heads-up' map with information covering a wide area. The map features a walking circle indicating walking times to nearby attractions and areas. The pylon features information including phone numbers, websites, QR Code, and NFC as well as Braille/tactile contact number and location reference. Smaller pylons feature in small scale or heritage environment. Pylons are located so as not to obstruct circulation.

W4. Flag Sign

The flag signs are fixed to smart poles and common poles. They reassure routes with place reference, directions similar/same as displayed on pylons. The flag signs are posted secondary to the pylon and where pylons are not suitable.

A variation of the flag sign has been developed for public transport directional signage. (W13)

W5. Finger Sign

Finger signs are fixed to smart poles and common poles. They apply where legibility from a longer distance is required, and where routes departing from decision points are few.

W6. Tactile Indicators (street name sign)

Tactile Indicators are signs that are placed at signalised pedestrian crossings adjacent to the pedestrian crossing push button to allow touch reading by people who are blind or have low vision and read at close range.

W7. Map

Maps are typically installed to freestanding and wall-mounted pylons. Maps can also be displayed individually to entries/exits to transport hubs, significant destinations, transport infrastructure such as bus stops, City of Sydney structures such as phone booths, tourist information bureaus and kiosks.

Maps are displayed in a 'heads-up' rather than a 'north-up' orientation as this aids navigation when reading the maps.

Where space is limited only the detail map will feature.

W8. Destination marker

A destination marker signals the arrival at a destination such as a significant park, civic building or place. It features the name of the destination and relevant interchangeable information. Additionally the marker can also feature interpretation about the place (history, flora fauna etc, depending on the destination). The graphics and displays feature on both sides of the marker.

W9. Interpretation Marker

The interpretation marker identifies a site, a place or a journey providing interpretation about the place (history, flora fauna etc, depending on the destination). It can be a stand alone marker or in proximity with a wayfinding pylon. The graphics and displays feature on both sides of the marker.

W10 - W12 and 14. Taxi Signage

The Taxi signage includes variations of the wayfinding pylon for Taxi Ranks and Taxi Stands.

A variation of the finger sign is also included in the Taxi signage family.

ABCDEFGHIJKLMNOPQRSTUVWXYZ

abcdefghijklmnopqrstuvwxyz

1234567890



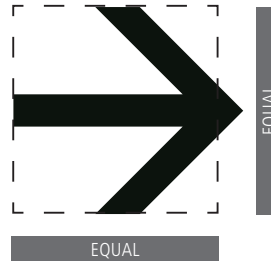

Typeface: Frutiger 57 Condensed

Tracking: -20

Kerning: Optical



Hierarchy of Directions

1.  Typical
2.  Where required
3.  Typical
4.  Where required
5.  Typical

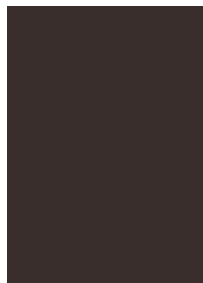

Colour for main body of pylon sign & background to all sign types.

To match Dulux powder coat Precious Metropolis Bronze Pearl Satin 9751-59003









Source: City of Sydney
"Public Domain Code"



Colour for Header and key graphic elements.

PMS 1235 C

Source: City of Sydney
"Our City, Your Brand"

-  Train
-  Bus
-  Ferry
-  Lightrail
-  Taxi rank
-  Phone number
-  Information
-  City of Sydney Logo
CO MO KO YO
Transparency 60%

PYLON SIGN



1. Header

Signs are clearly identified by a circle containing the 'information' symbol above head height for visibility from a greater distance.

2. Sign Address

The typography, colour coding and naming conventions are consistent with those on the Legible Sydney printed walking maps and other elements of the system.

3. Directional Information

Directions are listed in accordance with the messaging guidelines.

4. Detail Map

The detail map or '5-minute' map is used to find a destination. It clearly depicts walking routes, roads, buildings and landmarks.

5. Braille/tactile Contact Detail

Braille/tactile contact number and location reference.

6. Overview Map

The overview map or '15-minute' map is used to orientate the user in a larger context of the city and show how close areas are to each other. It provides the information needed to link areas of Sydney and instills the confidence to attempt longer distance walking journeys.

7. Contacts & Digital Media

Information including phone numbers, websites, QR Code and/or NFC.

8. Key

Streets and key destinations shown on maps are listed in alphabetical order and coded with the grid reference on the map.

9. City of Sydney Logo

The City of Sydney logo is a constant assurance of the systems quality, management and ownership.

Definition

The pylon is the cornerstone of the wayfinding system and the point of reference from where any relevant information can be obtained.

It is located at primary decision points only. The majority of the wayfinding signs, such as flag and fingersigns are placed along the routes to reassure the user.

Development

Size, shape and content of the doublesided pylon were developed after research into best practice and wayfinding systems in Australia and overseas.

Information content was developed considering optimal design in context with user needs.

The layout of graphics follows a format which is based on the principles of wayfinding, legibility, cognition, ergonomics and how users with disabilities interact with signage.

A rational display of hierarchical information onto interchangeable panels enables a continuing update of the information.

Materials and colours were developed and chosen in consultation with City of Sydney and are Sydney specific.

Graphic Components

The yellow pictogram in the header was chosen as it universally communicates a source of information.

The header also features the sign address on two levels, suburb/precinct/village and neighbourhood.

Directions typically feature six directions according to the place hierarchy.

To establish the order of directions, full scale mockups were prepared considering best practice and project-specific issues.

Typically the straight ahead direction is at the top of all directions followed by the direction to the right and finally the direction to the left.

Messages are supported by internationally recognised pictograms. Pictograms for transport were developed by Transport for NSW.

The typeface chosen for all lettering was Frutiger 57 Condensed tracking-20. Frutiger is indisputably a highly legible and proven typeface developed for signage environments.

Maps

The maps were developed with a cartographer. They feature a detailed heads-up map of the immediate area, a smaller heads-up map in different scale to inform of a larger area, approximately four times the area of the detail map. The maps feature a key.

The colours developed and chosen for the maps fulfill the criteria of optimum legibility in the exterior environment and optimal contrast between the colours.

A feature of the map is the distinct colour of pedestrian areas clearly denoting routes and places for the primary user.

Contact Information

Three critical contacts are listed with name, phone number, website and QR code. This allows users to tap into more detailed and up-to-date information.

Contact Information in Tactile and Braille Lettering

Pictograms, message, phone number and reference to the location of the pylon feature on an encapsulated graphic panel.

City of Sydney Logo

The logo of the City of Sydney features close to the base of the sign in a watermark-type application.

Frame

A frame of stainless steel plates protects the edges of the pylon, and creates a distinctive appearance against the faces of the pylon. The materials and colours of the pylon align with the City's street furniture design code.

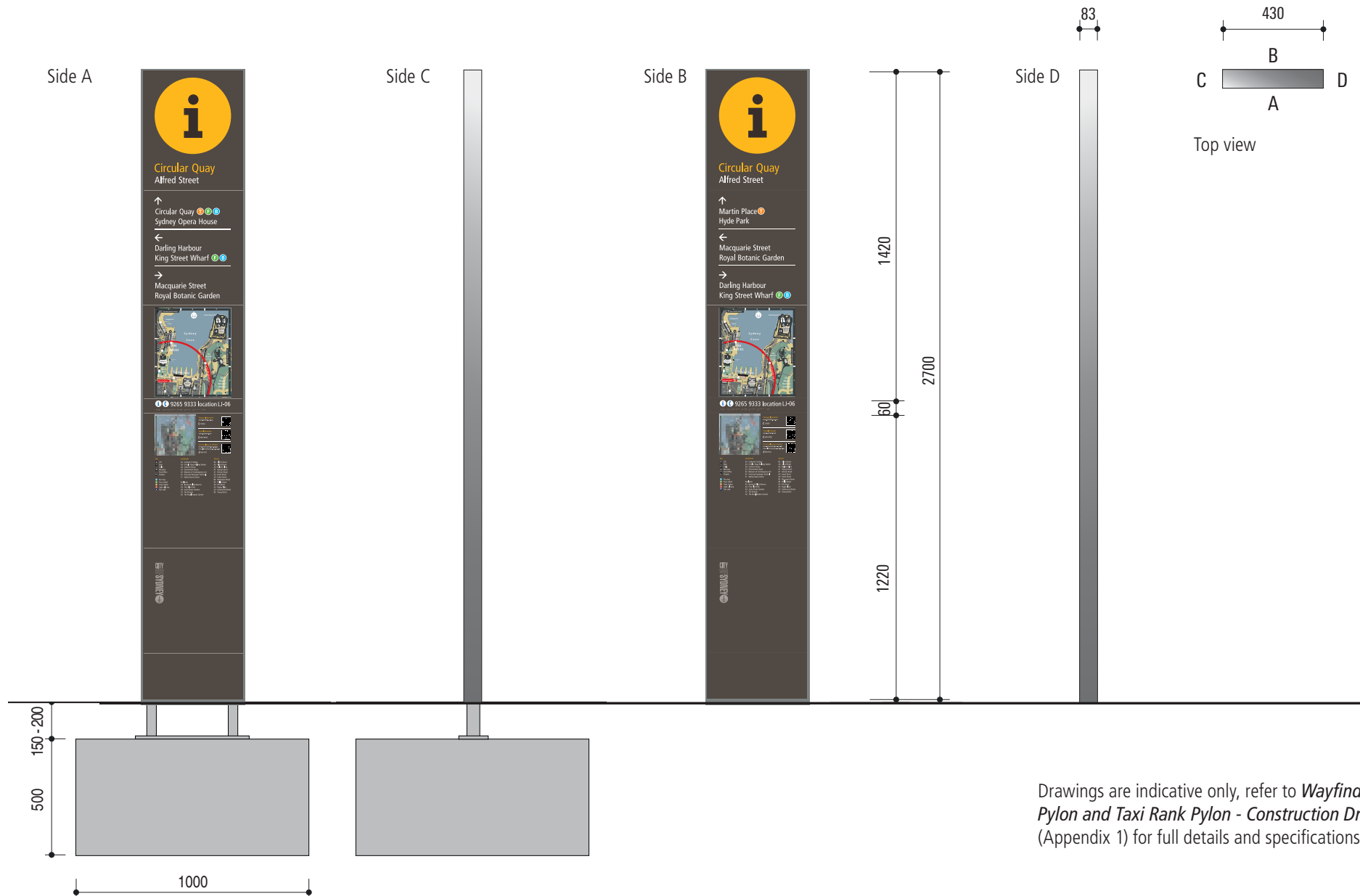

Drawings are indicative only, refer to *Wayfinding Signage Pylon and Taxi Rank Pylon - Construction Drawings* (Appendix 1) for full details and specifications.



Drawings are indicative only, refer to *Wayfinding Signage Pylon and Taxi Rank Pylon - Construction Drawings* (Appendix 1) for full details and specifications.

Construction Details

Refer to Appendix 1:

Wayfinding Signage Pylon and Taxi Rank Pylon - Construction Drawings.

Graphic Application

One of the following 2 graphic applications may be chosen by the City of Sydney on a case by case basis depending on the replacement and update requirements.

Graphic Application - Option 1

Reproduction as per artwork and colour specifications only.

1. Panels 1, 2, 4 and 5

Direct digital print on bronze 2-pac paint finish with 30% gloss 2-pac clear coat.

2. Panel 3

1.35mm acrylic panel, reverse paint sprayed to match Dulux Precious Metroplis Bronze Pearl Satin 971-59003. White acrylic Tactile letters, raised 1.15-1.35mm above surface, must be fully cut through the base panel, of a snug fit and not have free play in the panel.

Braille to be certified 316 grade stainless steel bearings, pressed into panel surface.

All tolerances must take into account expansion and contraction of materials.

Graphic Application - Option 2

Reproduction as per artwork and colour specifications only.

1. Panels 1, 2, 4 and 5

Photoanodising with antigrffiti and UV protection coating.

2. Panel 3

as per Option 1

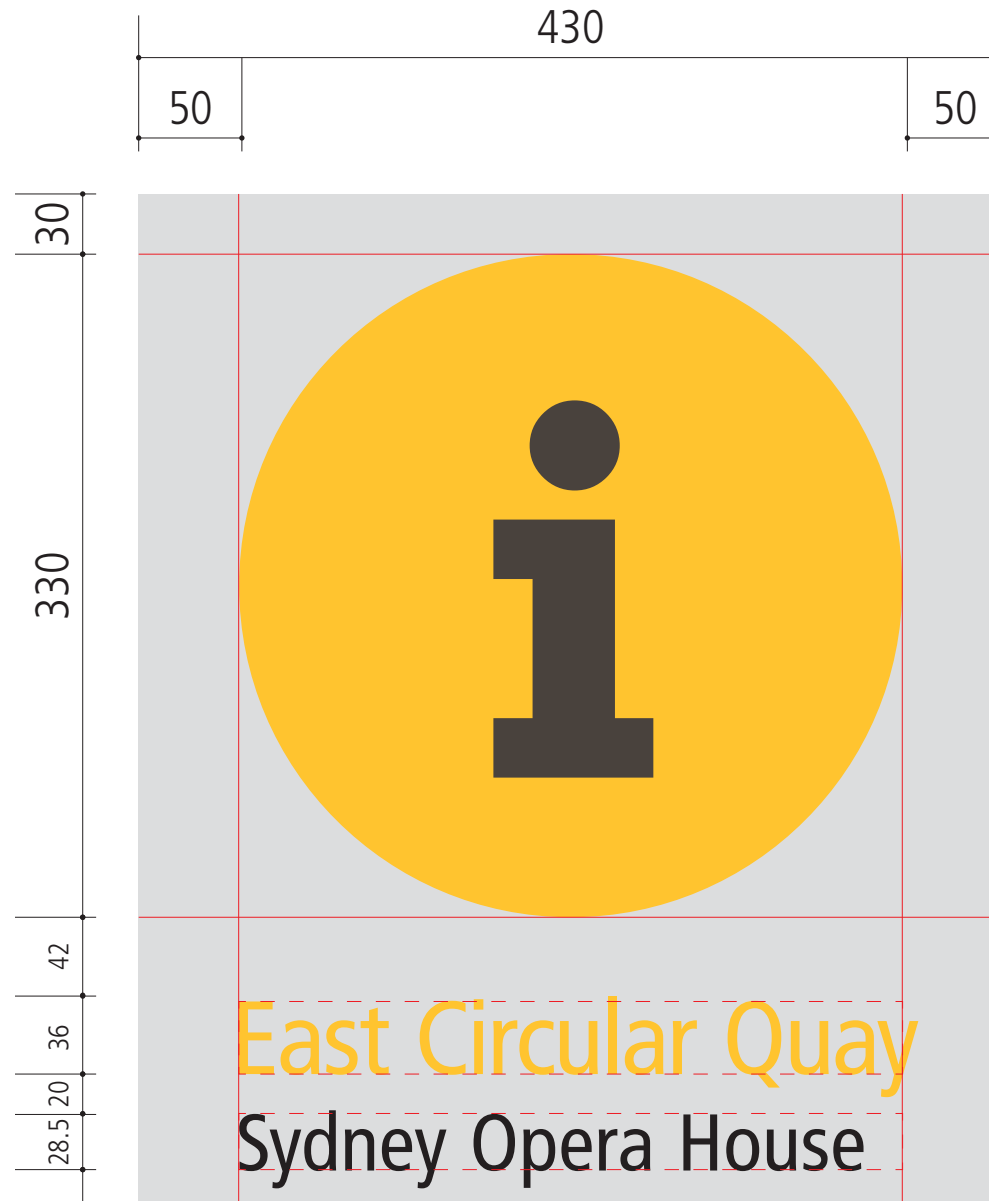

Note: Shown is a typical layout of graphics for directions within an overall guiding graphic grid. Quantity of destinations per direction may vary.

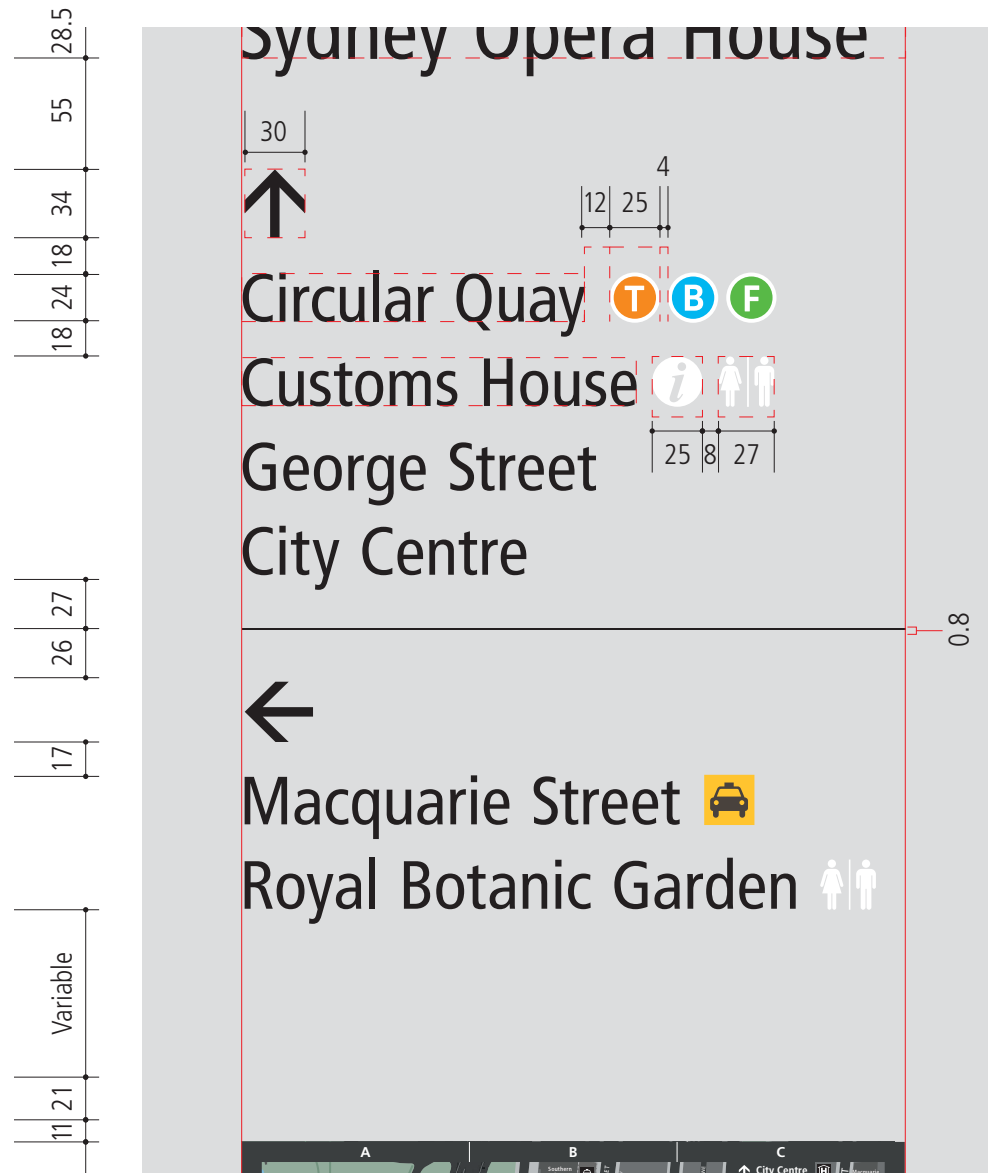

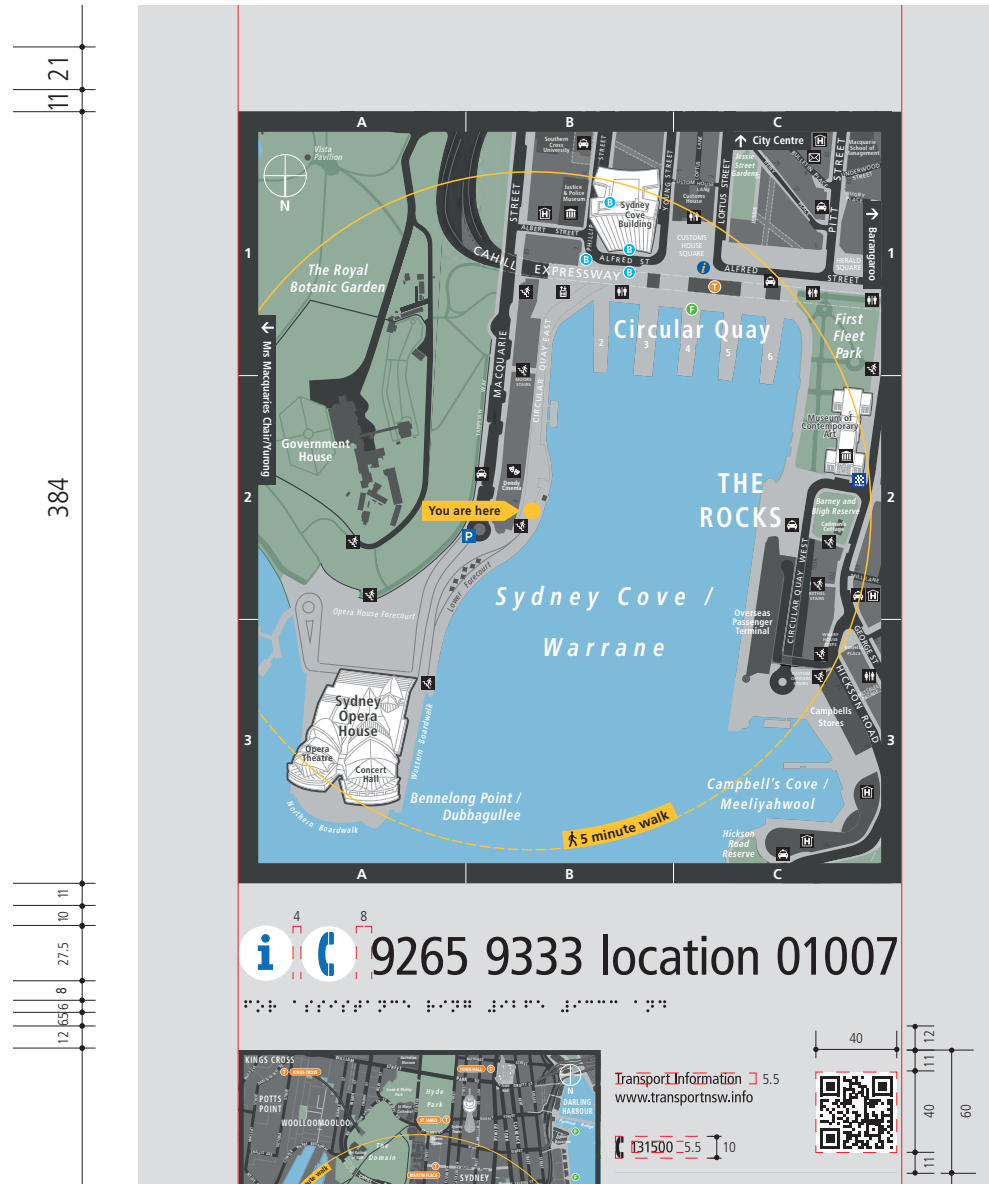

i

East Circular Quay
Sydney Opera House

↑
Circular Quay
Customs House
George Street
City Centre

←
Macquarie Street
Royal Botanic Garden

9265 9333 location 01007

Transport Information 5.5
www.transportnsw.info

131500 5.5 10

40
11 | 12
40
60

9265 9333 location 01007

Transport Information 5.5
www.transportnsw.info
131500 5.5 10

Tourist Information
www.sydney.com
8273 0000

City of Sydney access guide
www.cityofsydney.nsw.gov.au/accessibility
9265 9333

Key	Destinations	Streets
Lift	C2 Cadman's Cottage	C1 Alfred Street
Stair	C3 Campbells Warehouse	B1 Cahill Expressway
Toilet	B1 Circular Quay	C2 Circular Quay West
Hotel	B1 Justice & Police Museum	C3 Hickson Road
Museum	C1 Customs House	C1 Loftus Street
Post Office	B2 Dendy Cinema	B1 Macquarie Street
Theatre	A2 Government House	B1 Phillip Street
Restaurants	C1 Herald Square	C1 Pitt Street
Shopping	C2 Museum of Contemporary Art	B1 Young Street
Hospital	C3 Overseas Passenger Terminal	
Police Station	A3 Sydney Opera House	
Gallery		
Church		
Mosque		
Synagogue		
Temple		
	Parklands	
	C1 First Fleet Park	
	A1 The Royal Botanic Garden	

122 fixed | 17 | 191 (2 x column variable)

330

i

East Circular Quay
Sydney Opera House

↑
Circular Quay
Customs House
George Street
City Centre

←
Macquarie Street
Royal Botanic Garden

9265 9333 location 01007

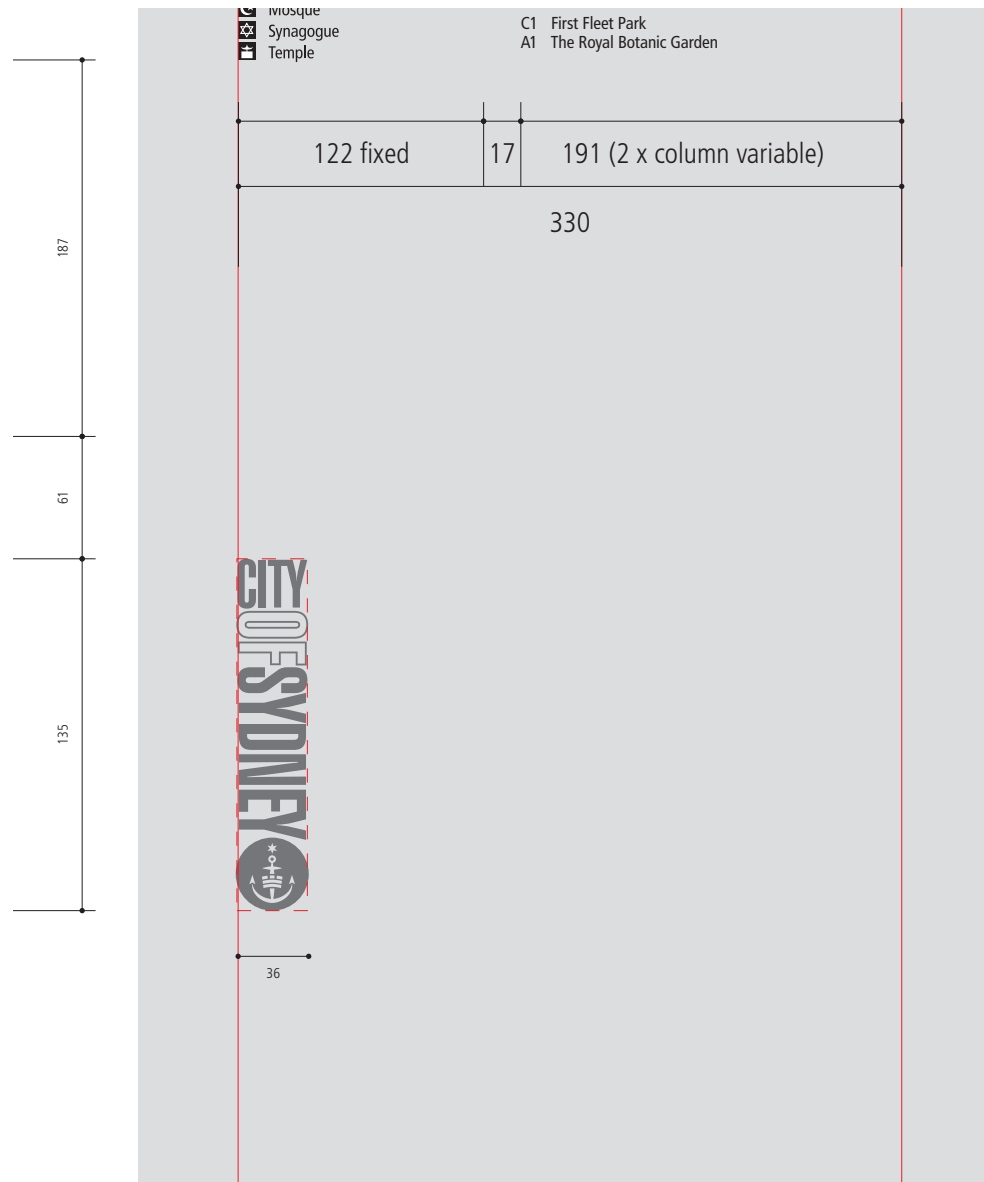

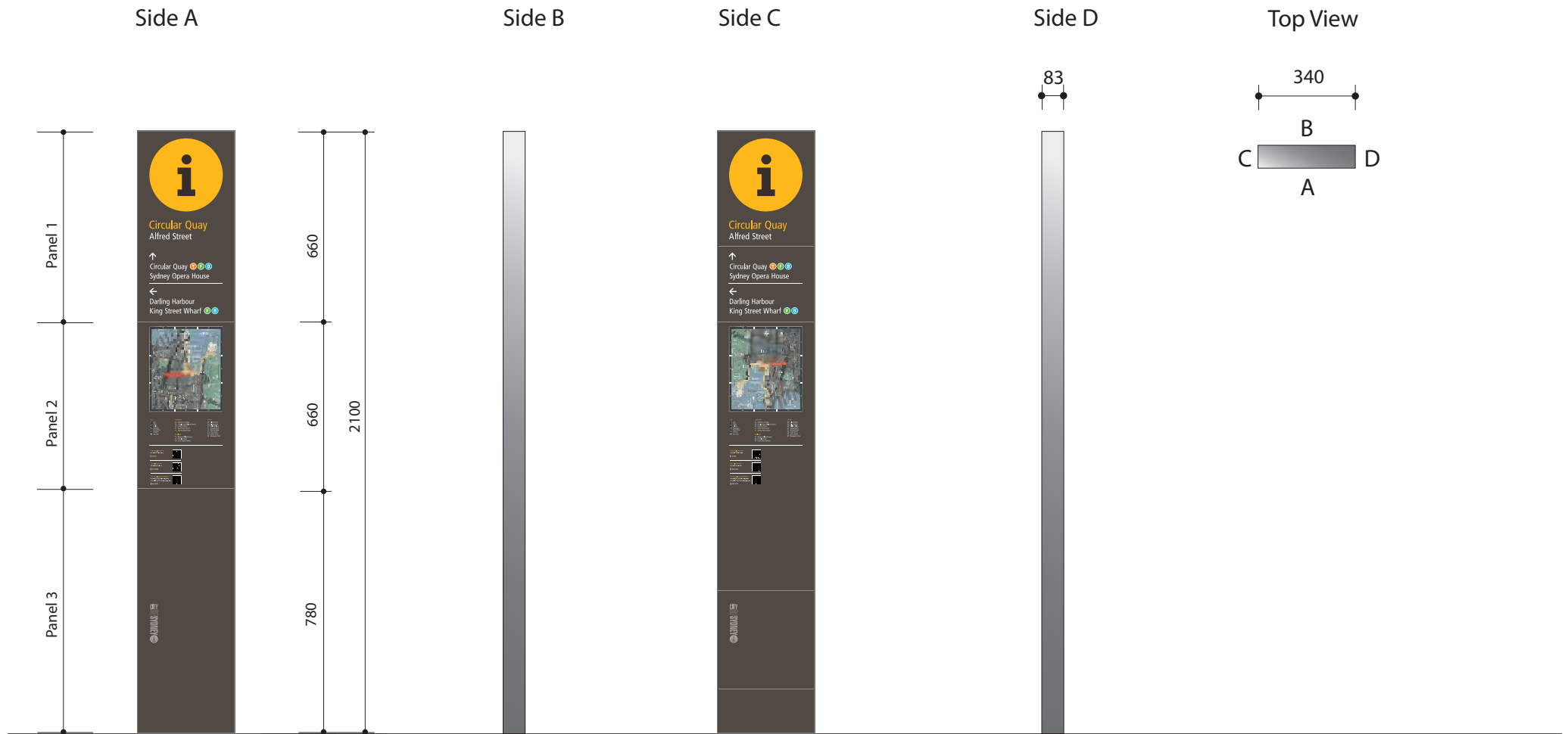

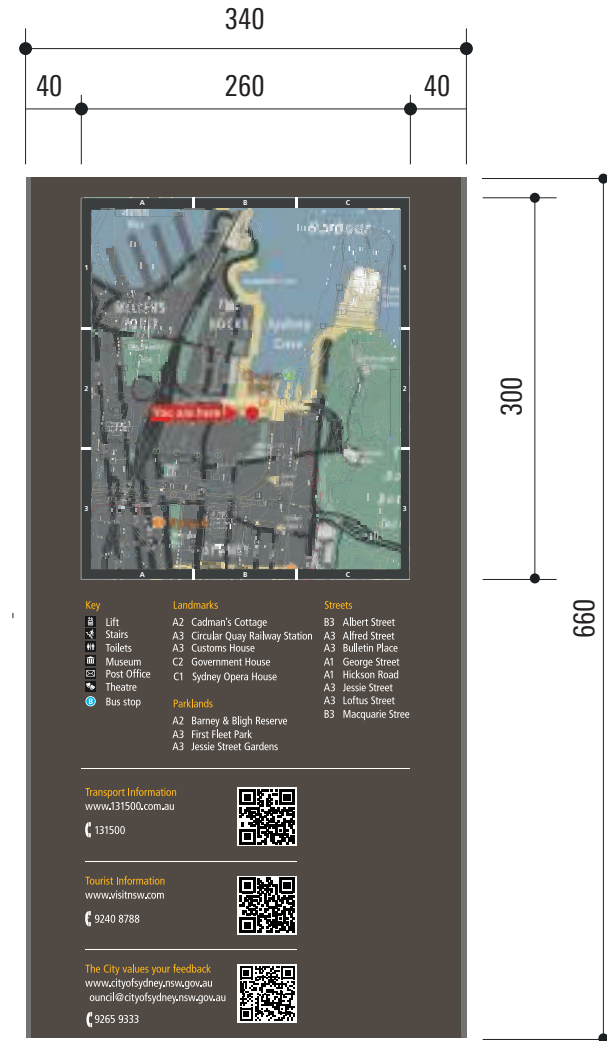
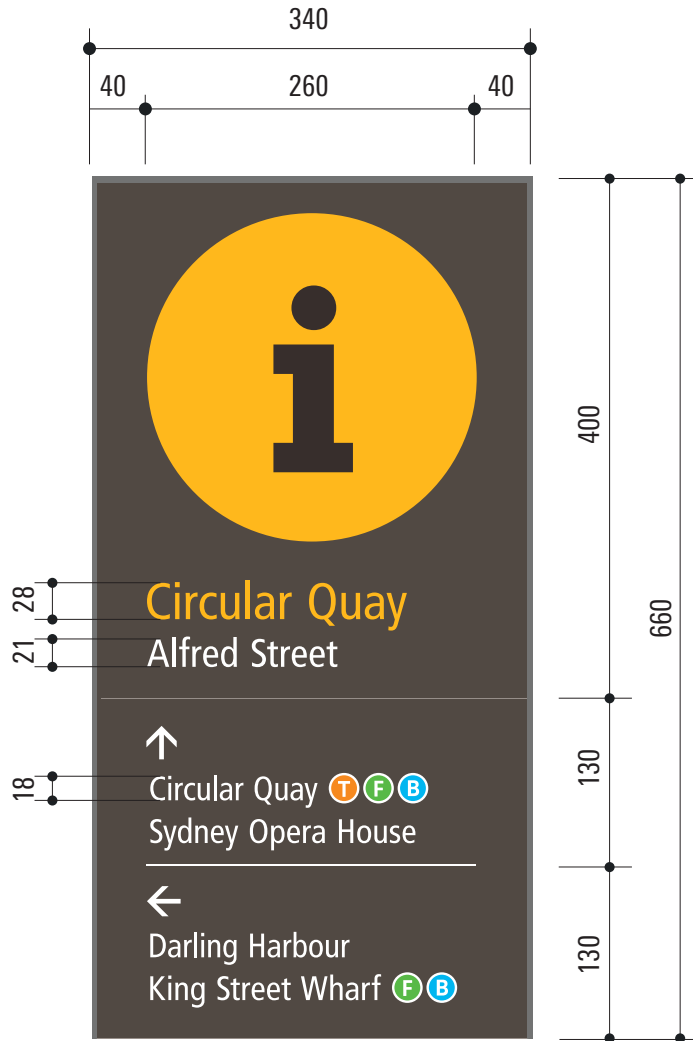

Note: Detail Map at the same scale as typical pylon. Cropping of map subject to client approval.

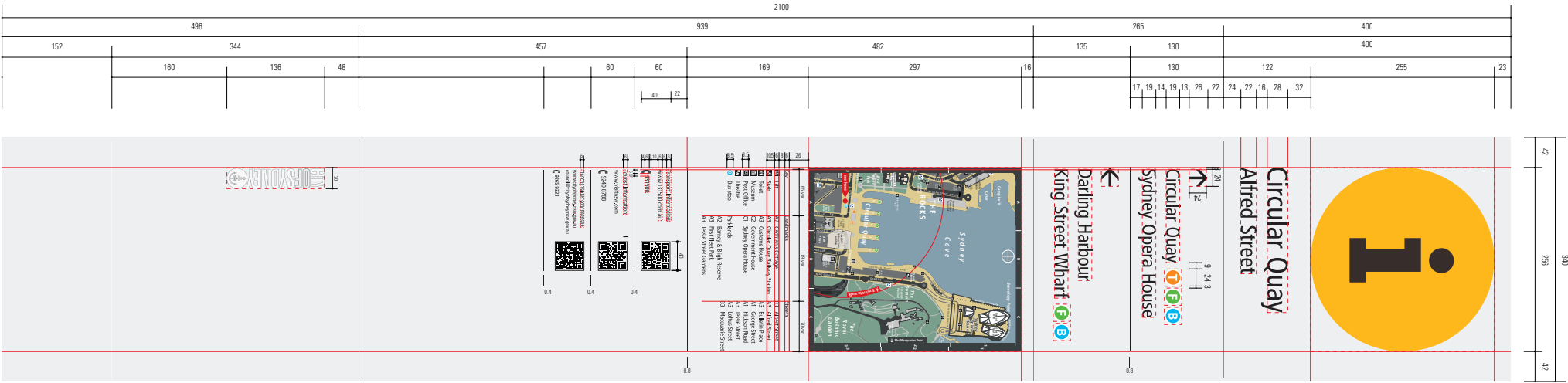

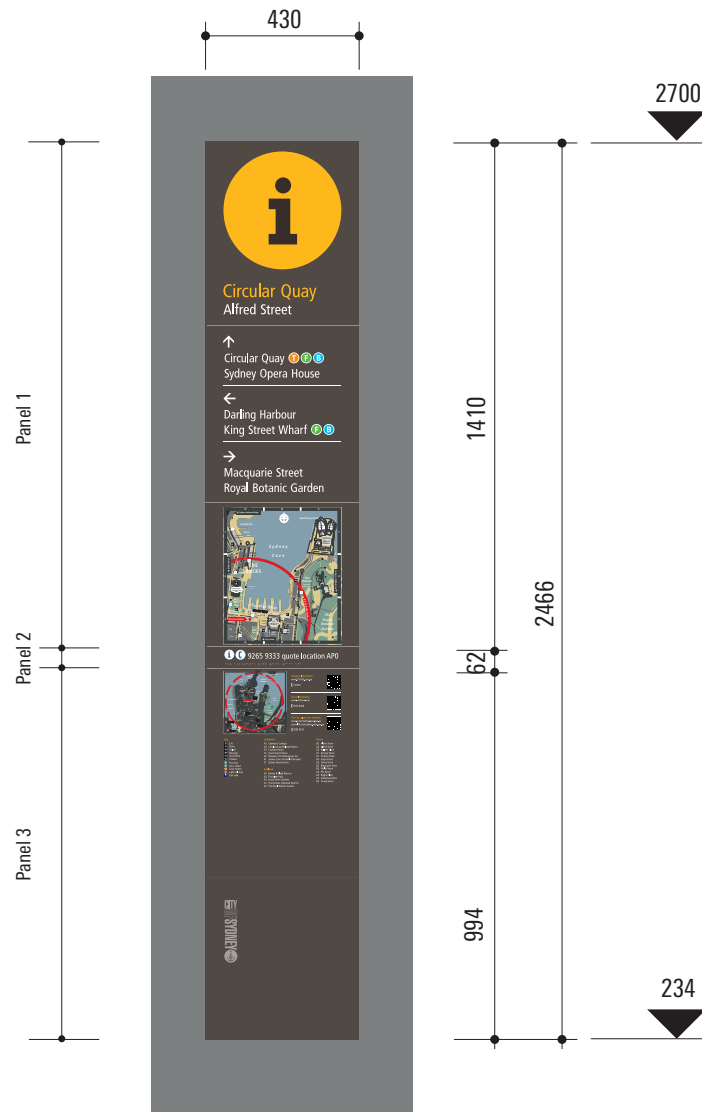

Frame

“Signlink” Grandeur (or similar approved) frame in Satin Natural Anodise (SNA) finish. Unit is 17mm thick.

Fixing Method

2 x “Signlink” proprietary product Split Batten (or similar approved) total 9.5mm thick.

Mechanical fixing, appropriate double sided tape.

Outer Frame

Nominal 6mm stainless steel 316 bar 2B finish on all 4 sides. Non-directional orbital finish to exposed surfaces. Edge mirror polished. Smooth outer edges.

Fixing of Frame components similar to method specified for Pylons. Frame bars 27mm wide and flush with face of frame.

Graphics

Reproduction as per artwork and colour specification only.

Graphics digitally printed.

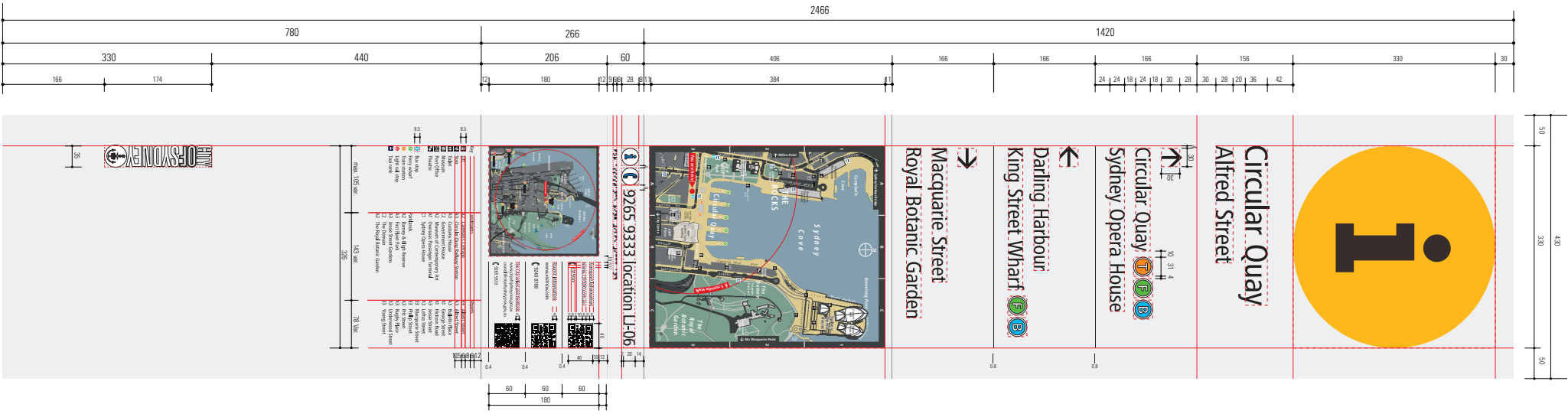



Frame

"Signlink" Grandeur (or similar approved) frame in Satin Natural Anodised (SNA) finish. Unit is 17mm thick.

Fixing Method

2 x "Signlink" proprietary product Split Batten (or similar approved) total 9.5mm thick. Mechanical fixing, appropriate double sided tape.

Outer Frame

Nominal 6mm stainless steel 316 bar 2B finish on all 4 sides. Non-directional orbital linish to exposed surfaces. Edge mirror polished. Smooth outer edges.

Fixing of Frame components similar to method specified for Pylons. Frame bars 27mm wide and flush with face of frame.

Graphics

Reproduction as per artwork and colour specification only.

Graphics digitally printed.

Note: Scale of Detail & Overview Maps are subject to evaluation and client approval.

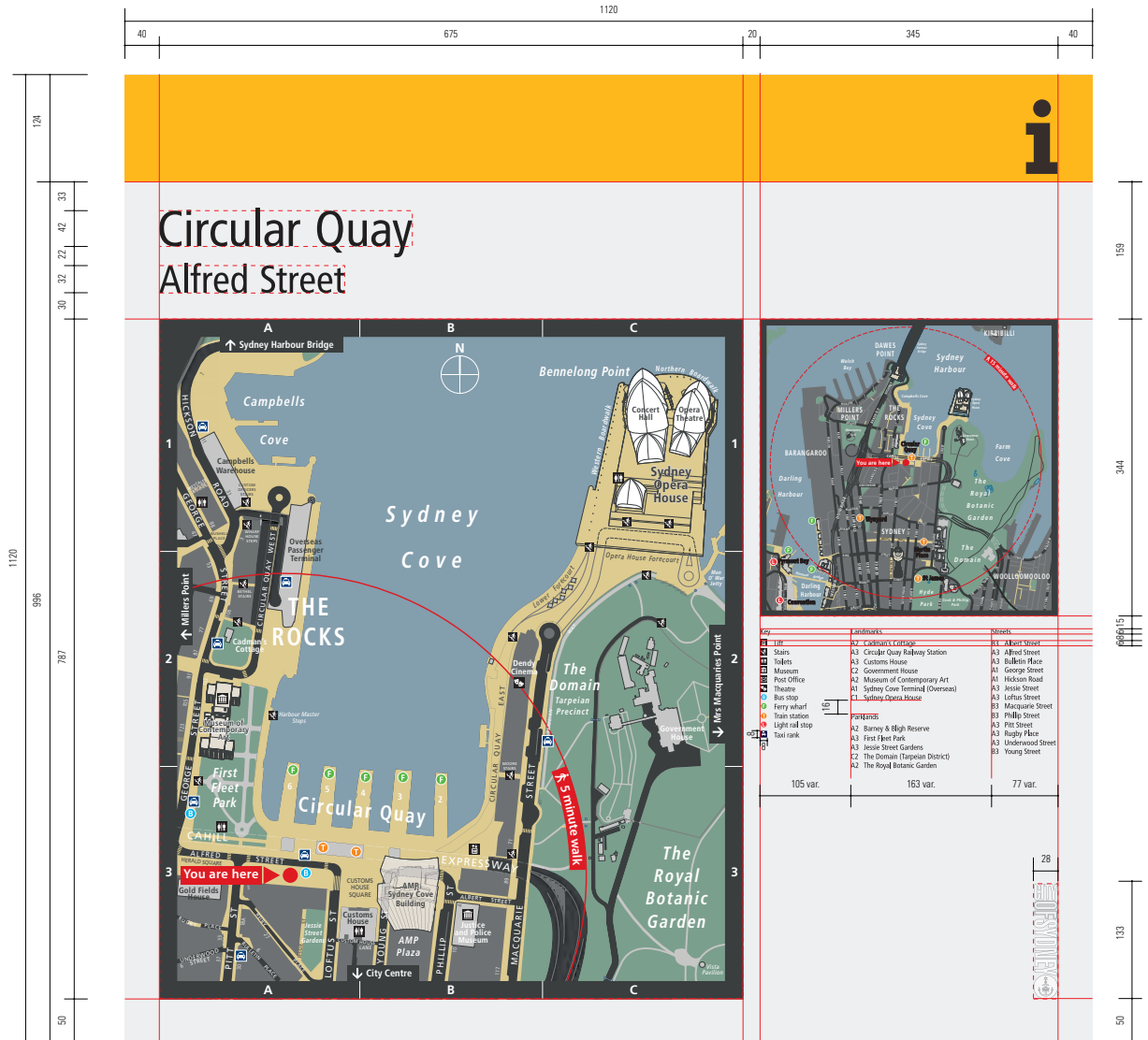

Note: Scale of Detail & Overview Maps are subject to evaluation and client approval.

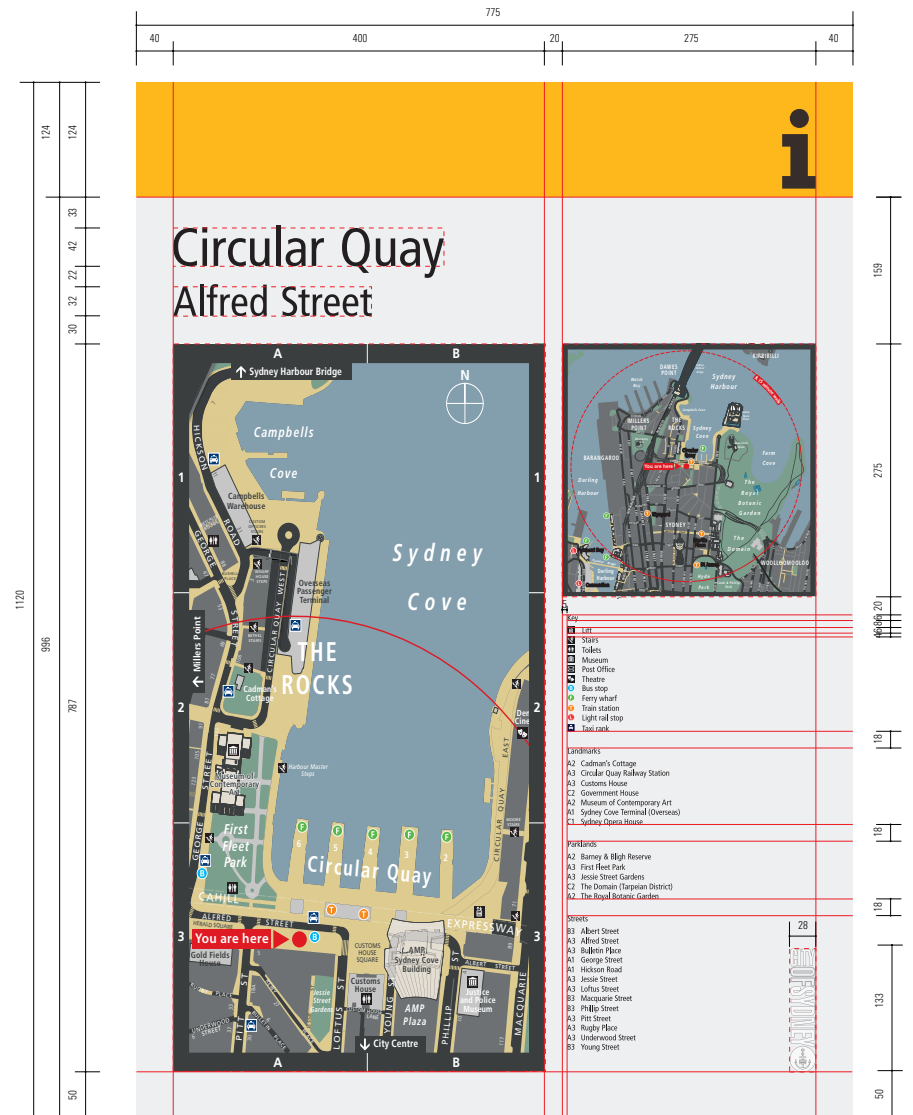

FLAG & FINGER SIGNS

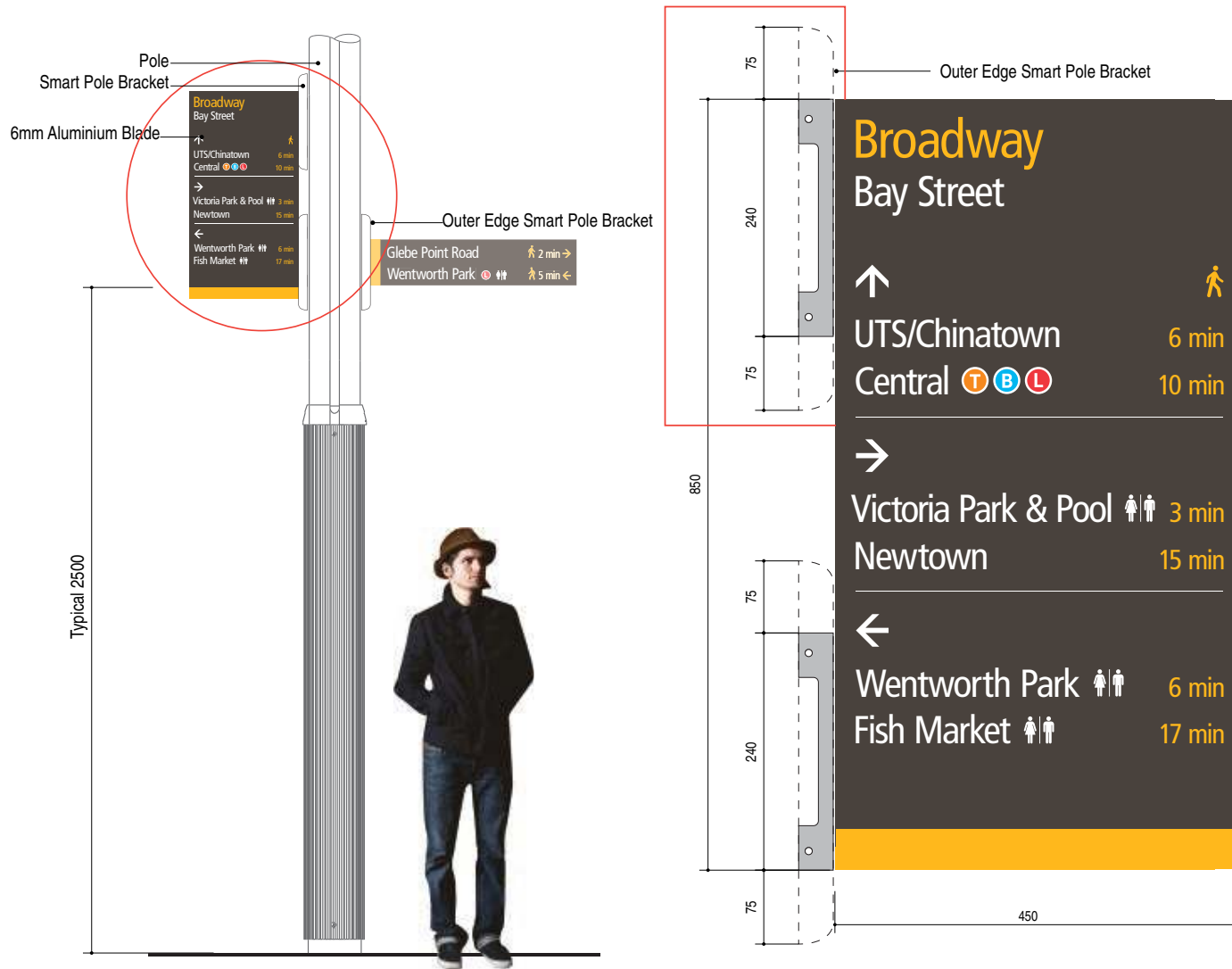

Flag & Finger Sign
Fit to Smartpole with brackets supplied by CoS

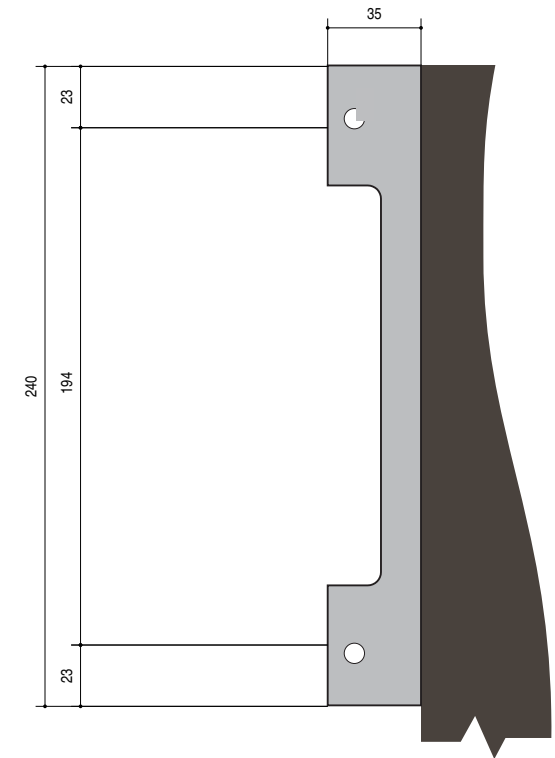

Specifications

6mm Aluminium panel, cut to suit bracket fixings, bronze 2-pac paint finish with 30% gloss 2-pac clear coat.

Graphic application: vinyl cut lettering and digitally printed graphics on white vinyl (for transport icons).

Reproduction as per artwork and colour specifications only.

Brackets for poles other than smart poles are to be 2-pac painted in bronze as specified for Legible Sydney signage system (refer to page 4).



Flag & Finger Sign
Fit to Smartpole with brackets supplied by CoS

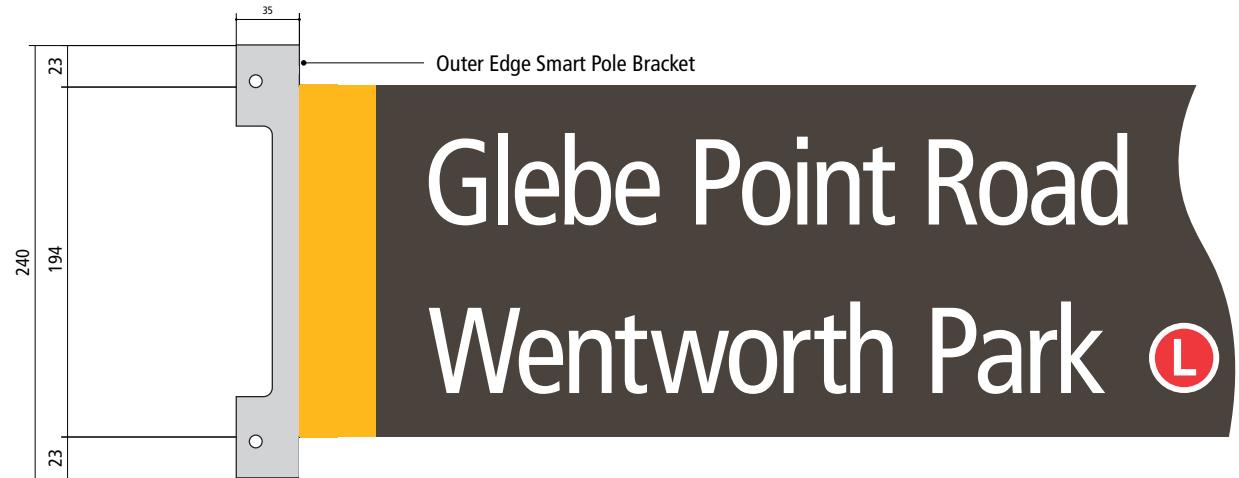
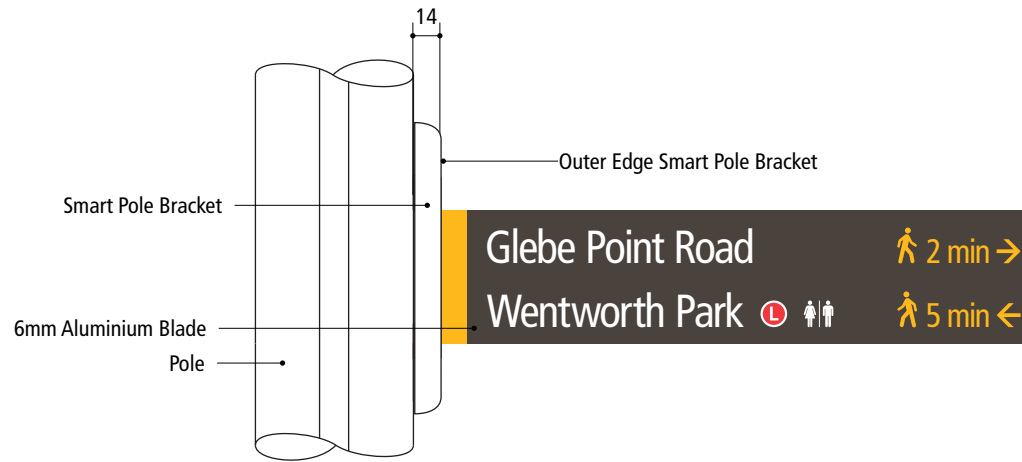

Note: Refer to page 25 for specifications

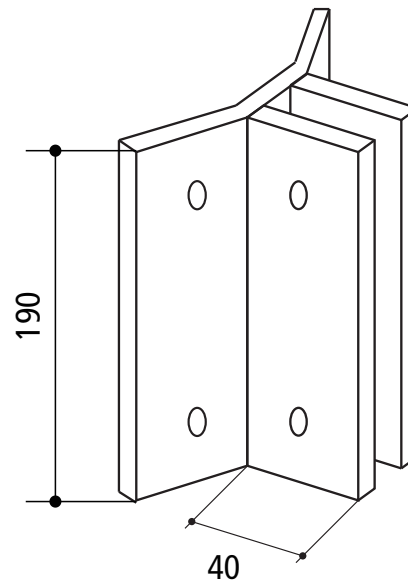
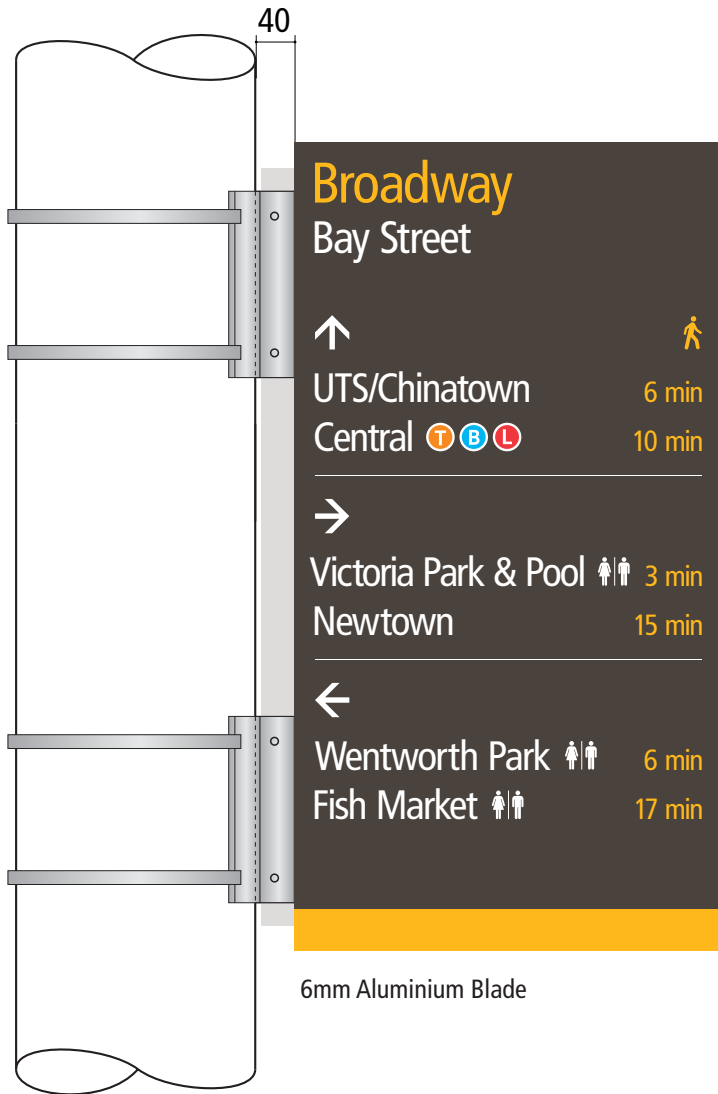

Standard T-shaped Aluminium Bracket with stainless steel banding

Note: Refer to page 25 for specifications

Note: Shown is a typical layout of graphics for directions within an overall guiding graphic grid.
 Quantity of destinations per direction may vary, but should not exceed 6 directions in total.

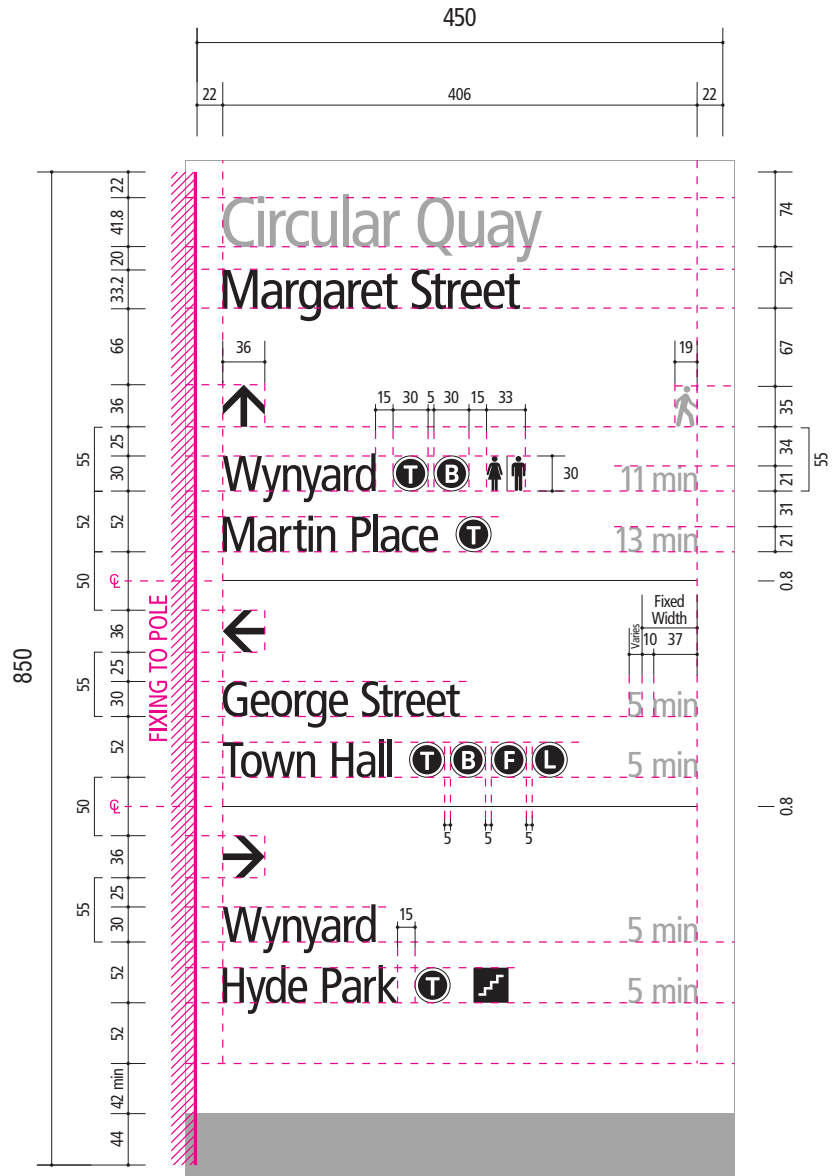

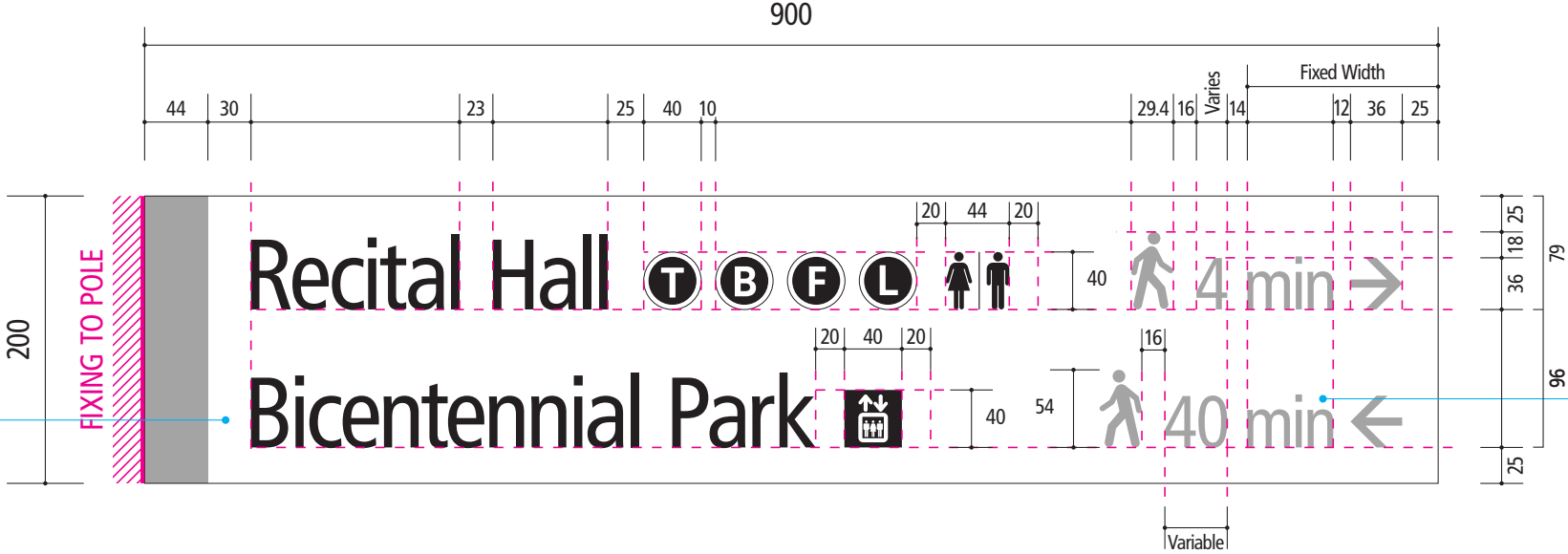

DESTINATION
 Frutiger LT 57 Condensed
 Cap X-height 140pt/35.7mm
 Optical Kerning
 Tracking -20

WALK TIME
 Frutiger LT 57 Condensed
 Cap X-height 140pt/35.7mm
 Optical Kerning
 Tracking -20

Note: Shown is a typical layout of graphics for directions within an overall guiding graphic grid.

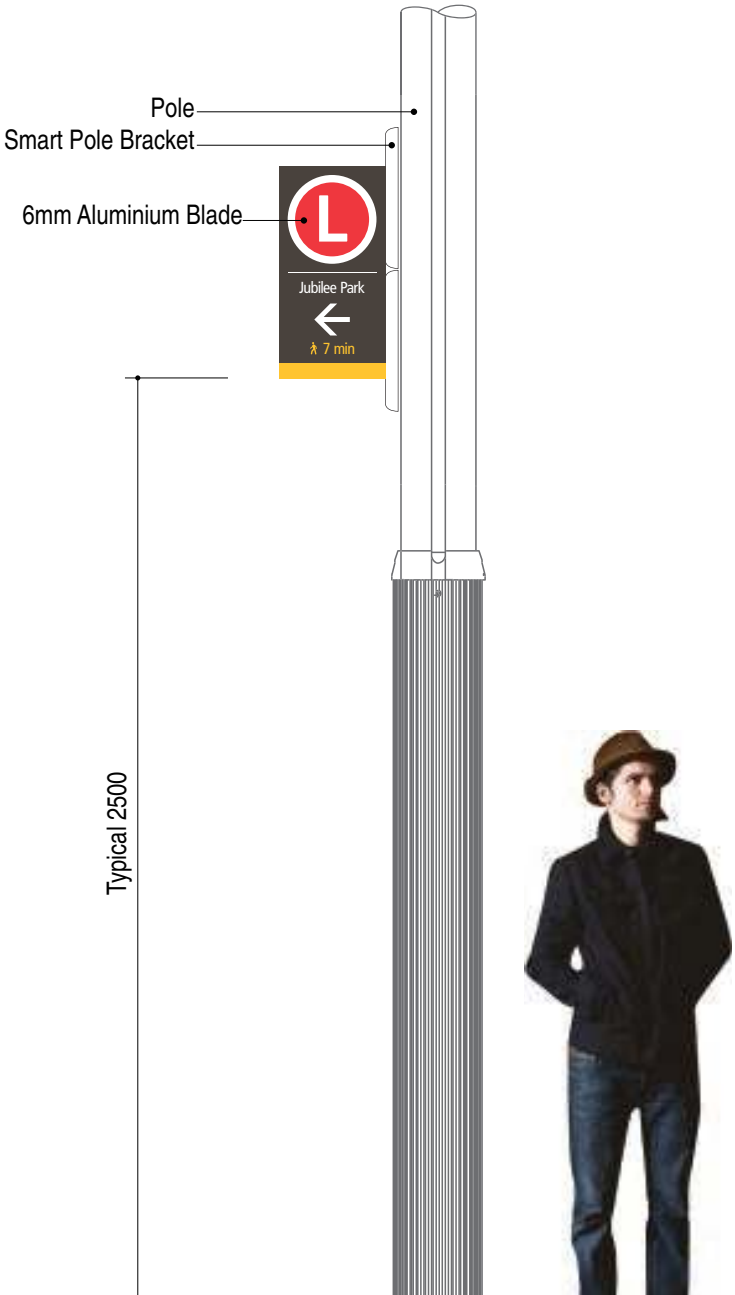

Note: Refer to page 25 for specifications

