

MEDIAN KERB (MK2)

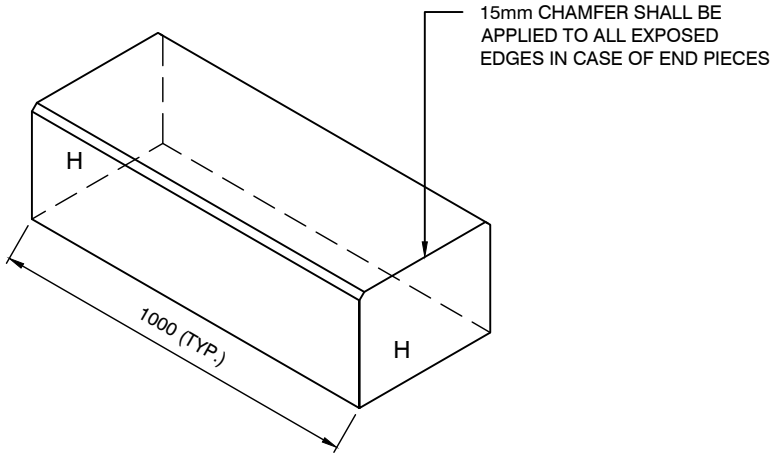

MEDIAN KERB WITH BULLNOSE (MK2BN)

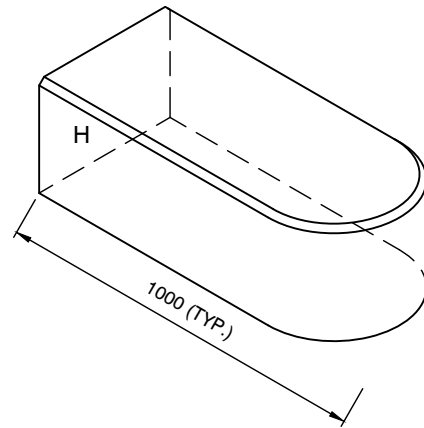

MEDIAN KERB END CHAMFER (MK2EC)

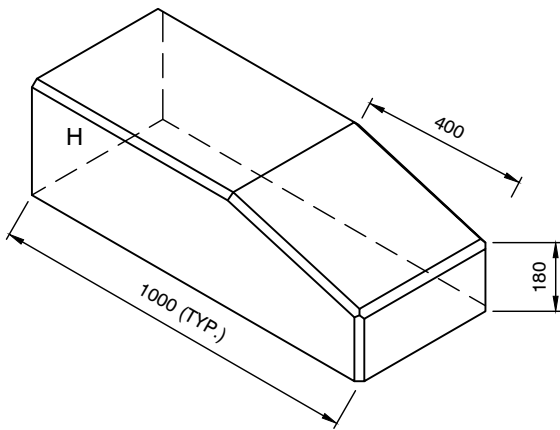

MEDIAN KERB DRIVEWAY CHAMFER (MK2DC)

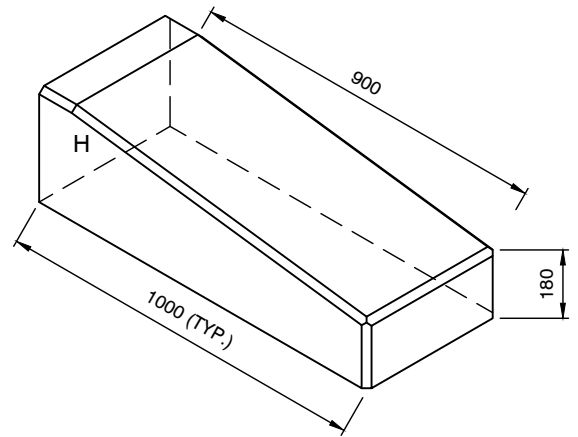

SCALE 1:20

MEDIAN KERB (MK2)

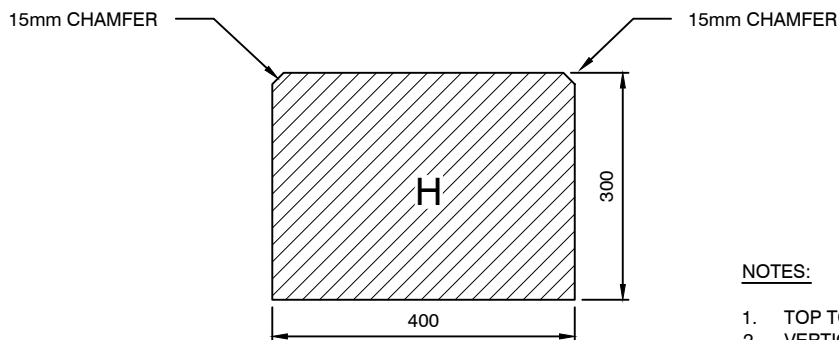

NOTES:

1. TOP TO HAVE EXFOLIATED FINISH.
2. VERTICAL EDGES TO HAVE SAWN FINISH.

SECTION 1:10

NOTE: ALL DIMENSIONS IN MILLIMETRES UNLESS OTHERWISE STATED