

STONE KERB SECTION

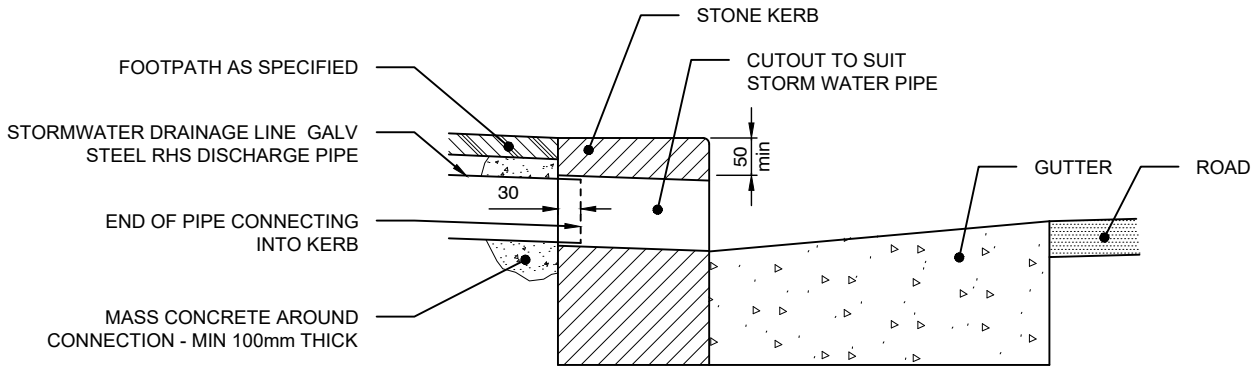

CONCRETE KERB SECTION

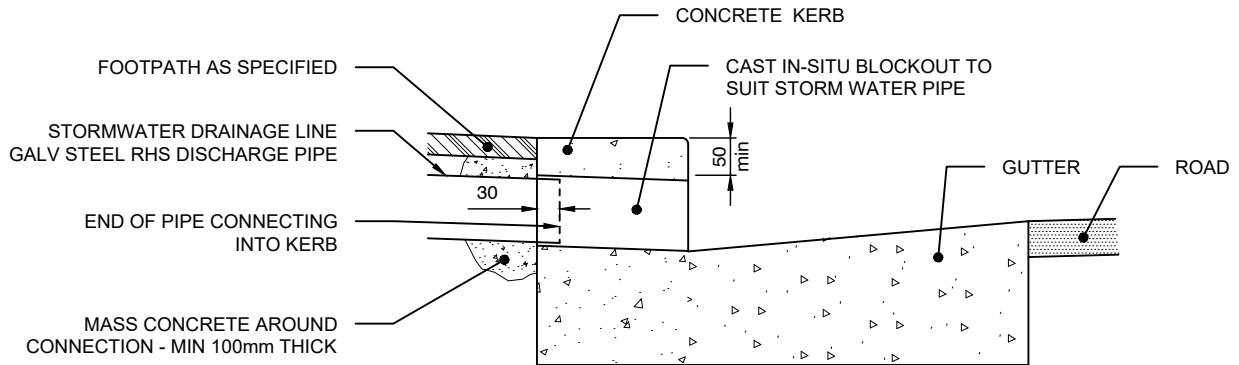

ELEVATION

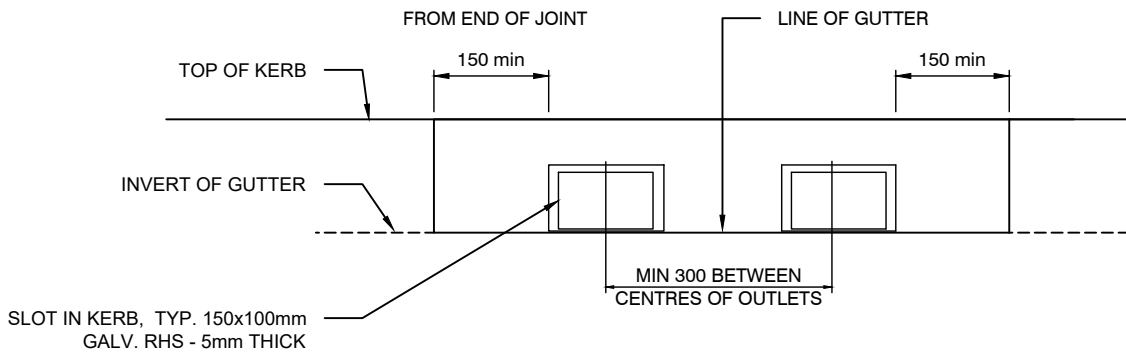

SCALE 1:10

NOTE: ALL DIMENSIONS IN MILLIMETRES UNLESS OTHERWISE STATED