

BARRIER KERB

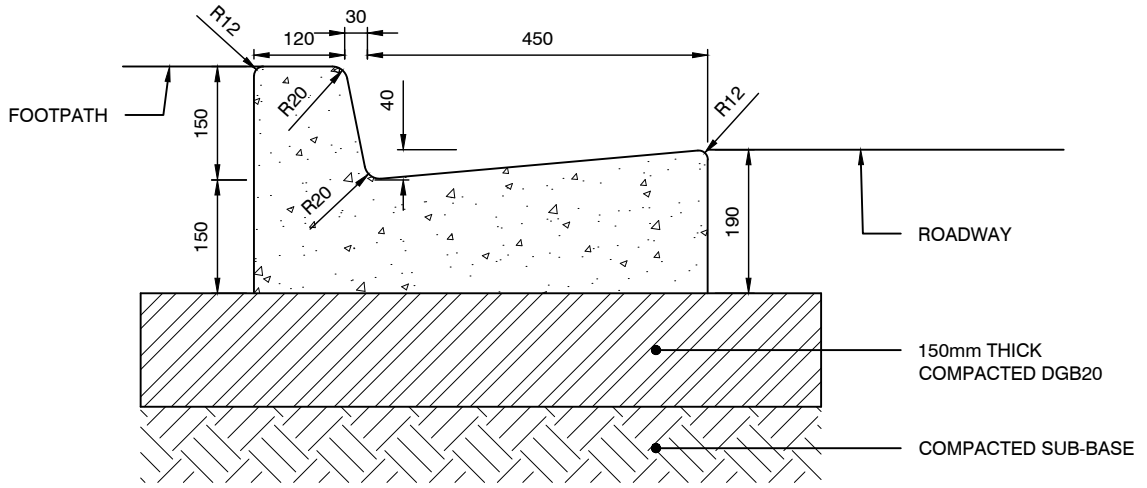

DISH CROSSING

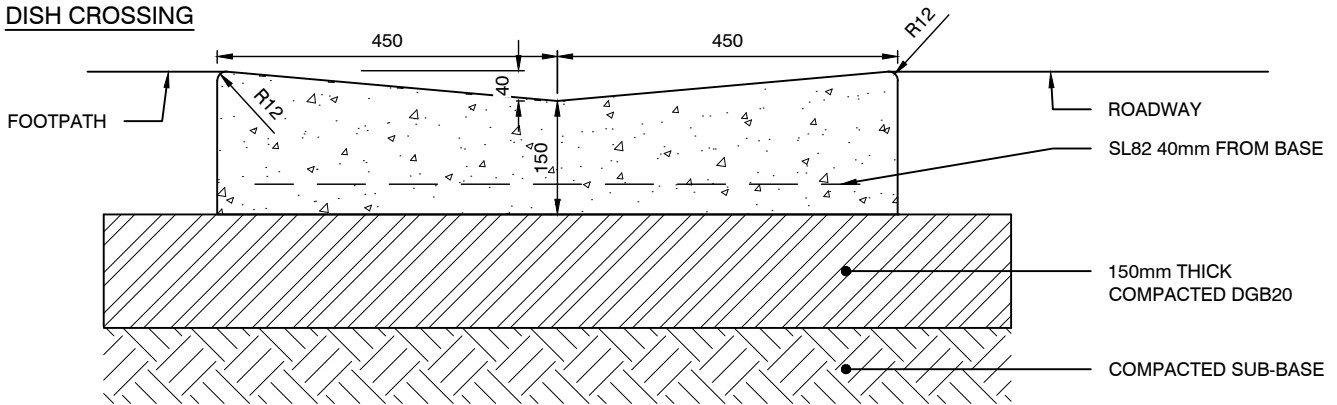

ROLL KERB

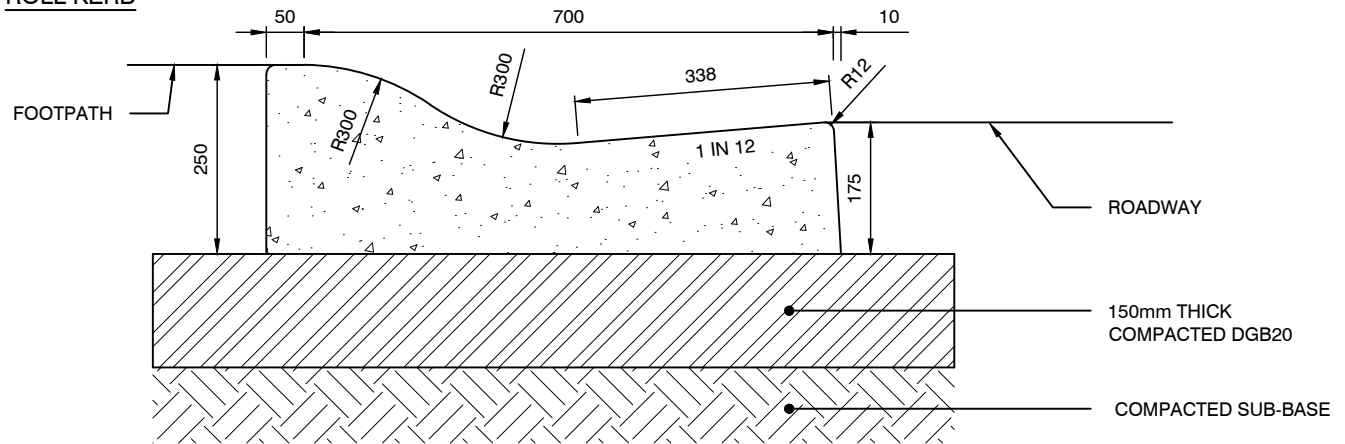

MOUNTABLE KERB

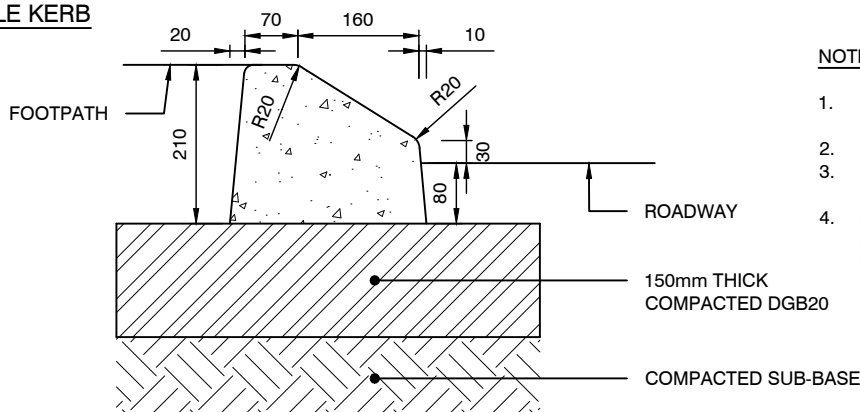

NOTES:

1. ALL KERBS TO BE MIN 25MPa CONCRETE UNLESS NOTED OTHERWISE.
2. ALL KERBS TO BE STEEL TROWEL FINISHED.
3. ALL EDGES SHALL BE TOOL FINISHED WITH 12mm RAD 50mm WIDE EDGING TOOL.
4. EXPANSION JOINTS SHALL BE PLACED AT 15m INTERVALS AND THE INTERFACE WITH OTHER FIXED STRUCTURES.

SCALE 1:10

NOTE: ALL DIMENSIONS IN MILLIMETRES UNLESS OTHERWISE STATED