

JUNCTION WITH BUILDING

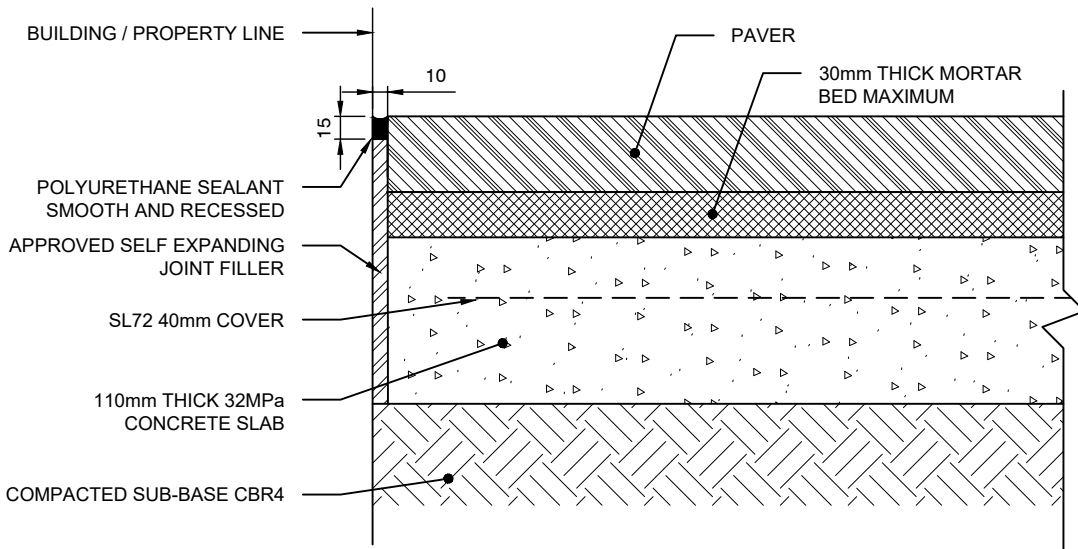

JUNCTION WITH BACK OF KERB

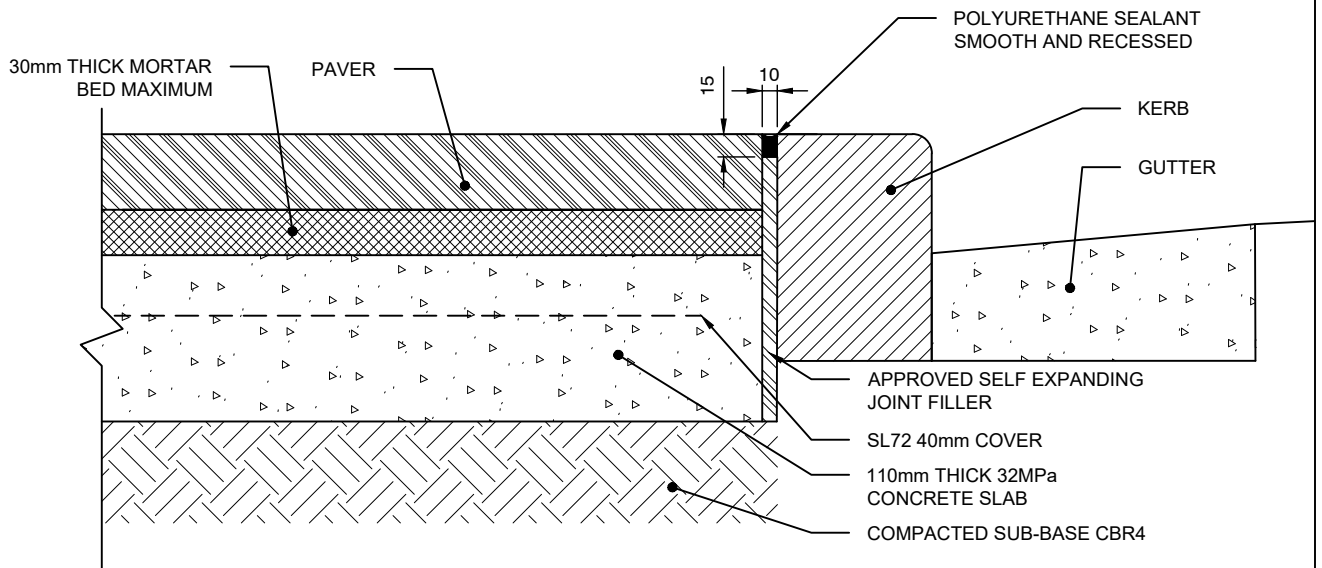

JUNCTION WITH EXISTING PAVEMENT

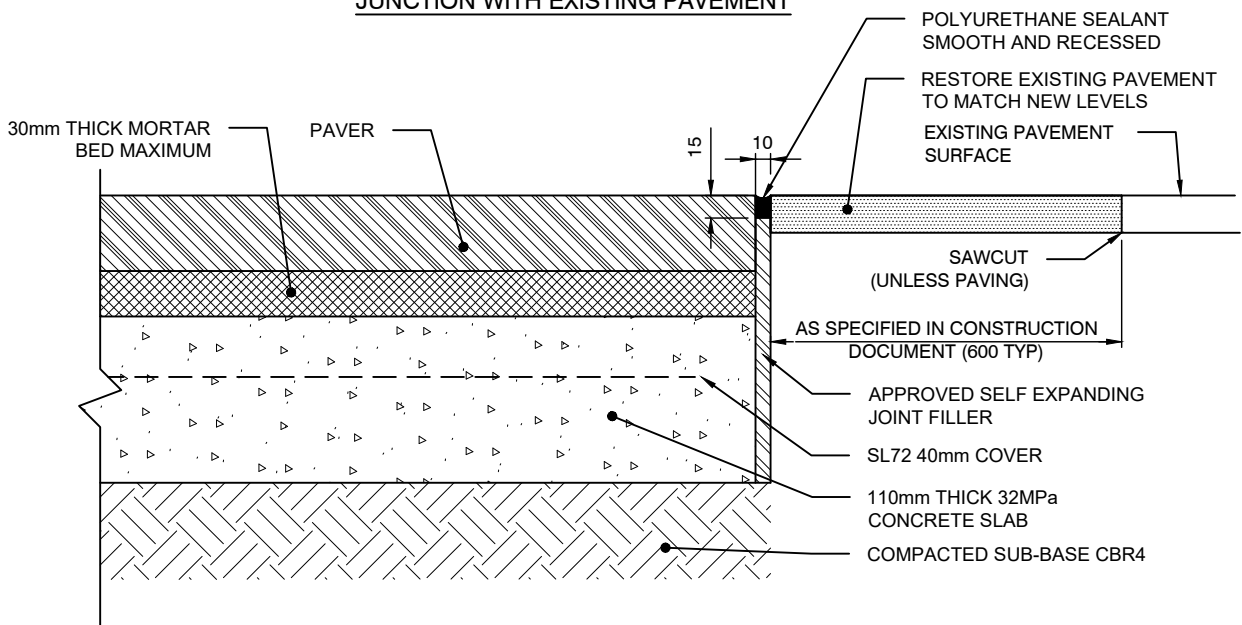

SECTION 1:5

NOTE: ALL DIMENSIONS IN MILLIMETRES UNLESS OTHERWISE STATED