

KERB TYPES:

- TYPE K(F): FULL HEIGHT
- TYPE K(KRF): PEDESTRIAN CHAMFERED TO FALL
- TYPE K(KR): PEDESTRIAN CROSSOVER

PLAN 1:50

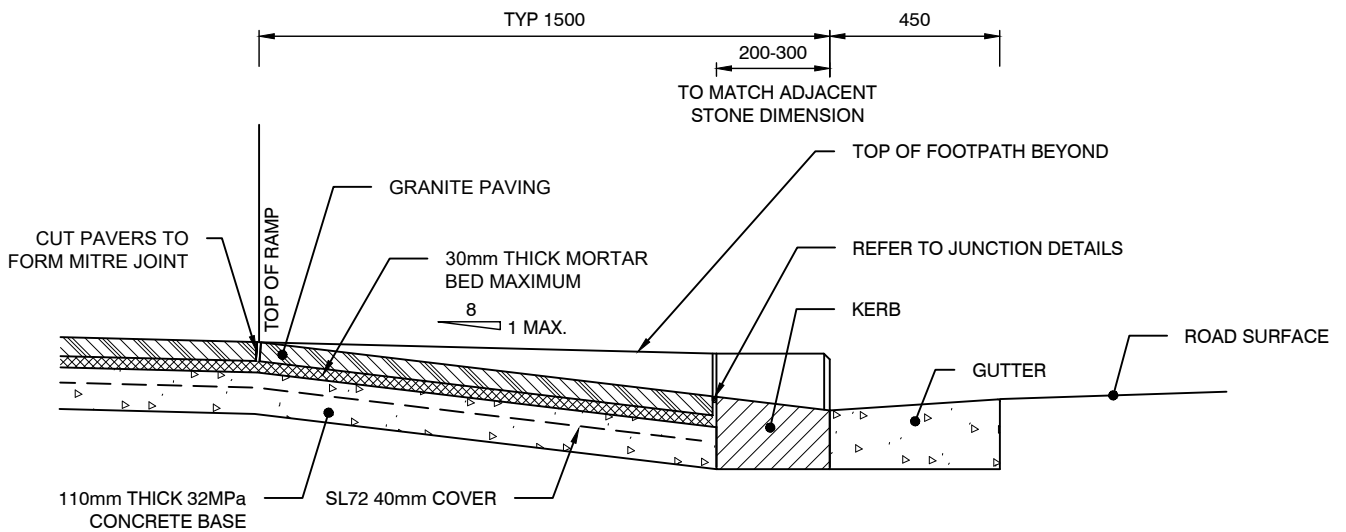

SECTION 1:20

NOTE: ALL DIMENSIONS IN MILLIMETRES UNLESS OTHERWISE STATED