

PAVER SIZES

TYPE A: 600 x 400 x 60mm
 TYPE B: 450 x 400 x 60mm
 TYPE C: 300 x 400 x 60mm
 TYPE D: SPECIAL CUT

KERB TYPES:

TYPE K(F): FULL HEIGHT
 TYPE K(V): VEHICULAR CROSSOVER
 TYPE K(V): VEHICULAR CHAMFERED TO FALL

NOTES:

1. DRIVEWAY TO BE GENERALLY PERPENDICULAR TO KERB LINE, UNLESS APPROVED OTHERWISE.
2. VERTICAL AND HORIZONTAL CLEARANCE SHALL BE CHECKED BY THE DESIGNER IN ACCORDANCE WITH AS2890.1.

PLAN

1:50

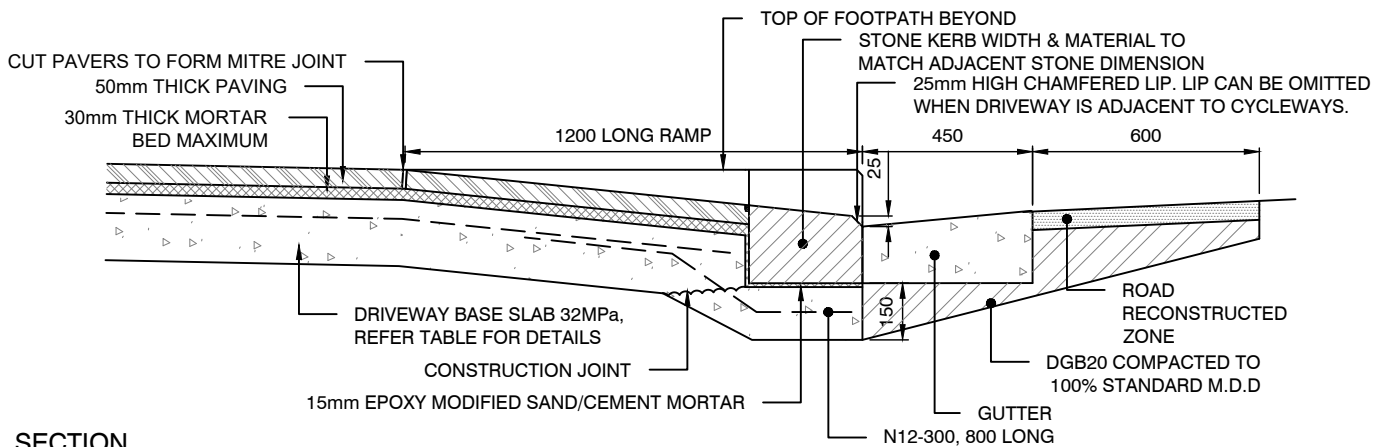

SECTION

1:20

DRIVEWAY SPECIFICATIONS			
DRIVEWAY USE	CONCRETE STRENGTH	THICKNESS	REINFORCEMENT
SINGLE RESIDENTIAL	32MPa	150mm	SL82 LOCATED CENTRALLY
MULTI RESIDENTIAL	32MPa	200mm	SL82 LOCATED CENTRALLY
COMMERCIAL/ INDUSTRIAL	32MPa	250mm	TWO LAYERS SL82 50mm COVER TOP & BOTTOM

NOTE: ALL DIMENSIONS IN MILLIMETRES UNLESS OTHERWISE STATED