

PLAN 1:50

NOTES:

1. DRIVEWAY TO BE GENERALLY PERPENDICULAR TO KERB LINE, UNLESS APPROVED OTHERWISE.
2. FOR NARROW FOOTPATHS, LENGTH OF RAMP TO BE REDUCED TO 900mm, OR LAYBACK ONLY TO BE USED IN APPROVED APPLICATIONS.
3. FOR DRIVEWAYS WIDER THAN 6.0m A TOOL JOINT SHALL BE PROVIDED ALONG THE CENTRE OF THE DRIVEWAY.
4. CONCRETE TO BE MINIMUM 32MPa.

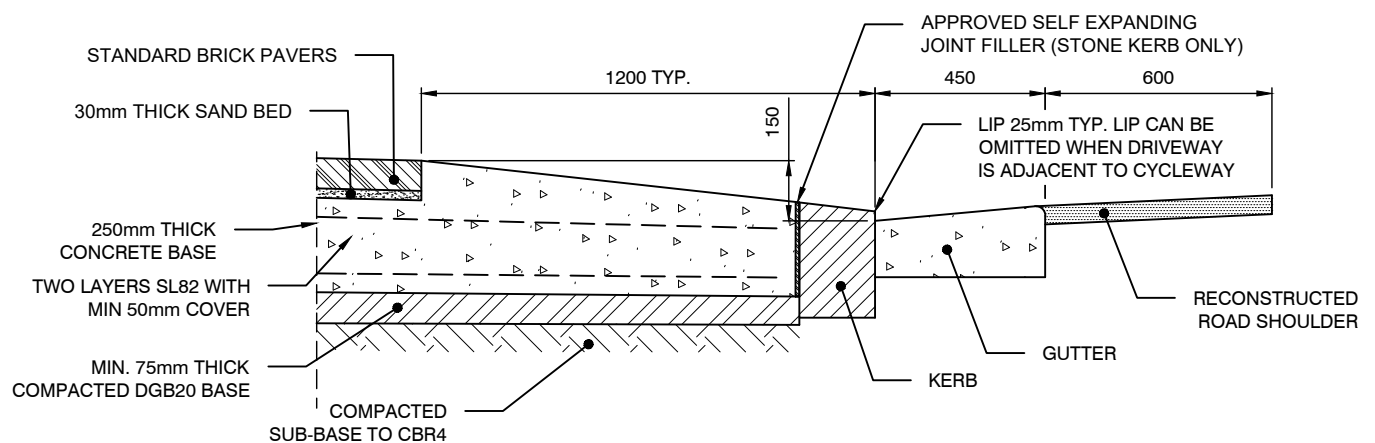

SECTION 1:20

NOTE: ALL DIMENSIONS IN MILLIMETRES UNLESS OTHERWISE STATED