

**PLAN**  
1:50

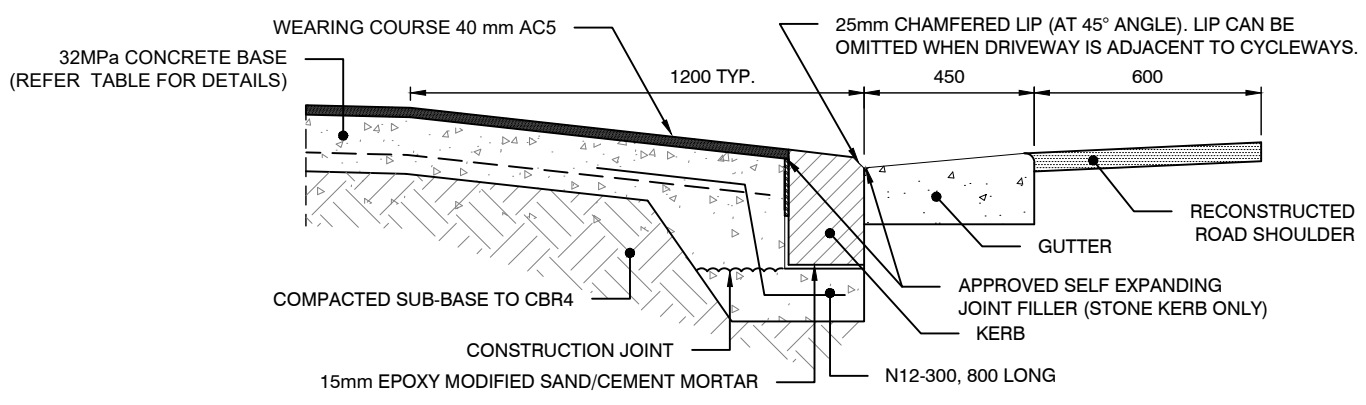

**SECTION ( WITH STONE KERB )**  
1:20

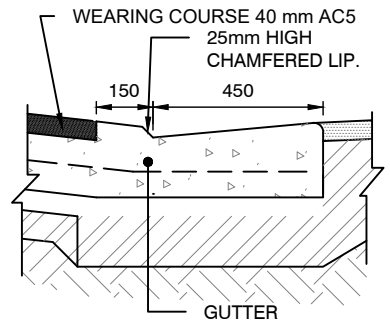

**SECTION ( WITH CONCRETE KERB )**  
1:20

DRIVEWAY SPECIFICATIONS			
DRIVEWAY USE	CONCRETE STRENGTH	THICKNESS	REINFORCEMENT
SINGLE RESIDENTIAL	32MPa	150mm	SL82 CENTRALLY LOCATED
MULTI RESIDENTIAL	32MPa	200mm	SL82 CENTRALLY LOCATED

**NOTES:**

1. DRIVEWAY TO BE GENERALLY PERPENDICULAR TO KERB LINE, UNLESS APPROVED OTHERWISE.
2. FOR NARROW FOOTPATHS, LENGTH OF RAMP TO BE REDUCED TO 900mm, OR LAYBACK ONLY TO BE USED IN APPROVED APPLI
3. DRIVEWAY TO BE GENERALLY PERPENDICULAR TO KERB LINE, UNLESS APPROVED OTHERWISE.
4. VERTICAL AND HORIZONTAL CLEARANCE SHALL BE CHECKED BY THE DESIGNER IN ACCORDANCE WITH AS2890.1.
5. CONCRETE TO BE MINIMUM 32MPa

SECTION 1:20

NOTE: ALL DIMENSIONS IN MILLIMETRES UNLESS OTHERWISE STATED