

**PLAN**

1:50

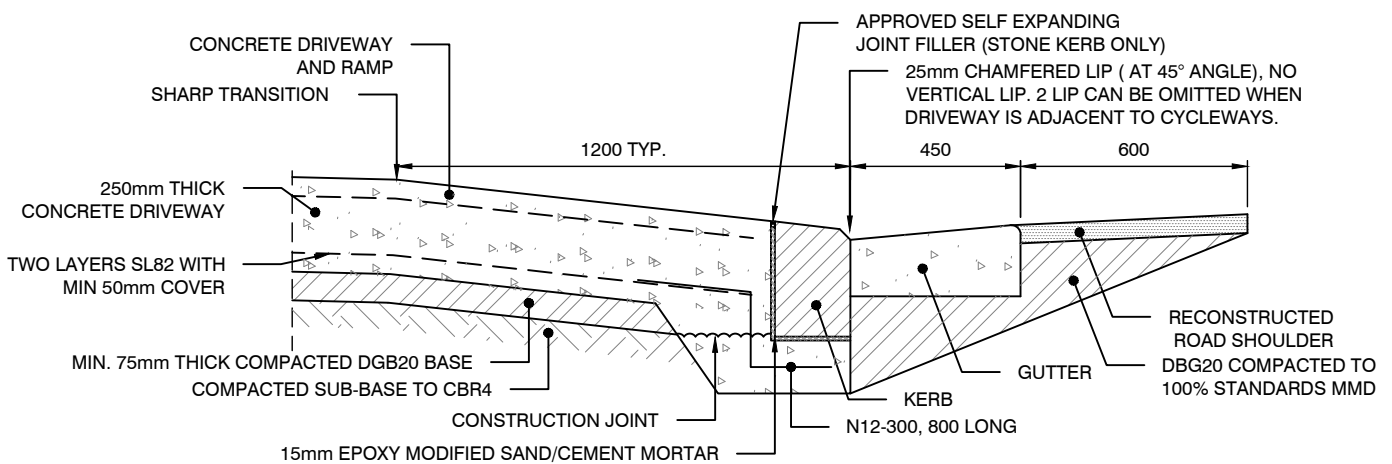

**SECTION ( WITH STONE KERB)**

1:20

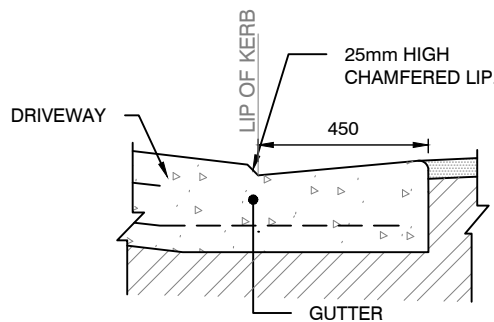

**SECTION ( WITH CONCRETE KERB)**

1:20

1. THIS DRIVEWAY SUIT COMMERCIAL VEHICULAR CROSSINGS SUBJECTED TO AXLE LOADING HEAVIER THAN 10 TONNES.
2. DRIVEWAY TO BE GENERALLY PERPENDICULAR TO KERB LINE, UNLESS APPROVED OTHERWISE.
3. VERTICAL AND HORIZONTAL CLEARANCE SHALL BE CHECKED BY THE DESIGNER AS PER AS2890.1.
4. FOR NARROW FOOTPATHS, LENGTH OF RAMP TO BE REDUCED TO 900mm, OR LAYBACK ONLY TO BE USED IN APPROVED APPLICATIONS.
5. FOR DRIVEWAYS WIDER THAN 6.0m A TOOL JOINT SHALL BE PROVIDED ALONG THE CENTRE OF THE CONCRETE DRIVEWAY.
6. CONCRETE TO BE MINIMUM 32MPa.
7. TYPE OF KERB TO SUIT SYDNEY STREET CODE.

NOTE: ALL DIMENSIONS IN MILLIMETRES UNLESS OTHERWISE STATED