

EXPANSION JOINT

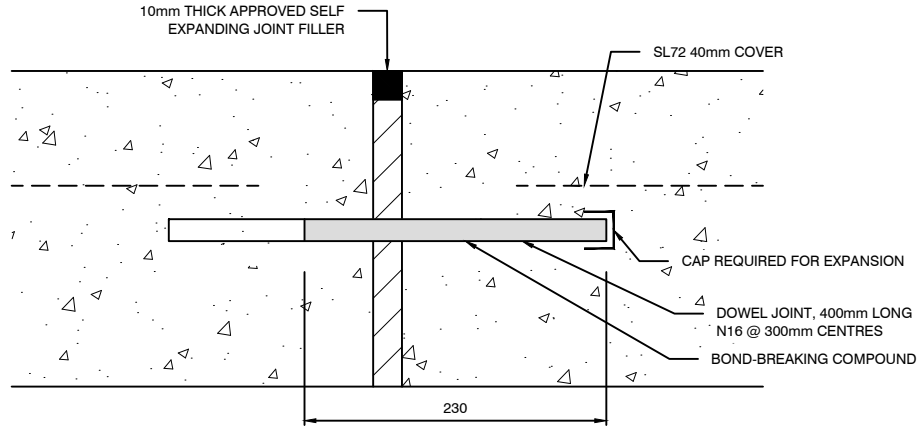

NOTE: BOND-BREAKING COMPONENT AND END CAP MAY BE REPLACED WITH A PURPOSE-MADE DOWEL SLEEVE.

CONTRACTION/CONTROL JOINT

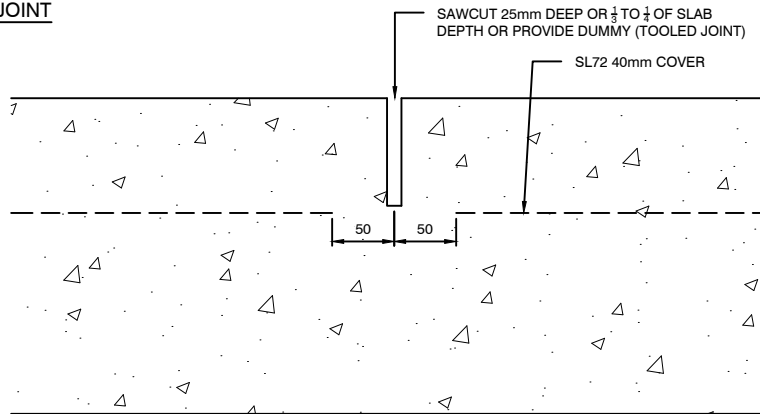

CONSTRUCTION JOINT

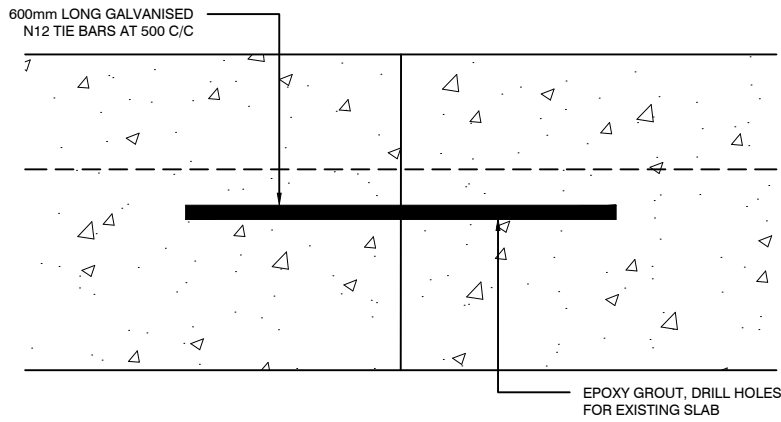

ISOLATION JOINT

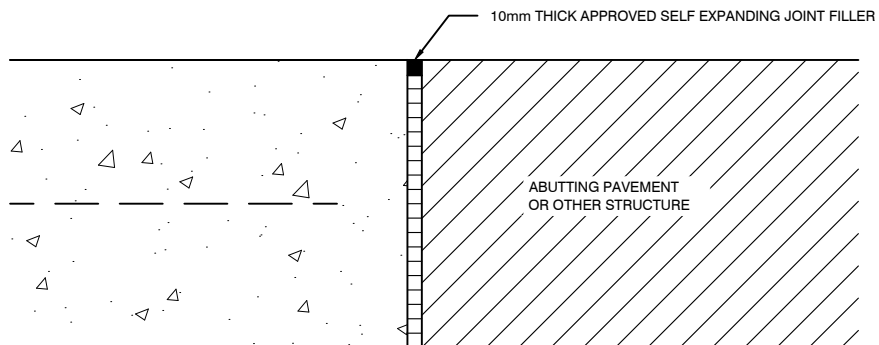

NOTE: ALL DIMENSIONS IN MILLIMETRES UNLESS OTHERWISE STATED