

PLAN 1:50

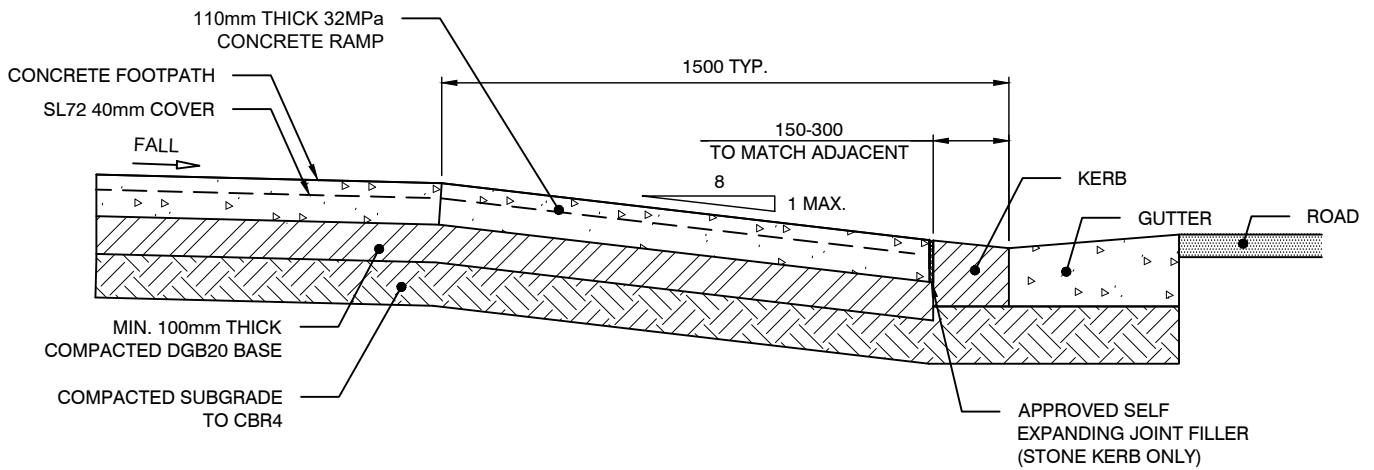

SECTION 1:20

NOTES:

1. ALL DIMENSIONS IN MILLIMETRES UNLESS OTHERWISE STATED.
2. THE 45° WING ANGLE ON KERB RAMPS IS THE GENERAL STANDARD AND RMS RECOMMENDATION. IF RESTRICTED BY SITE CONDITIONS, THE WING ANGLE CAN BE REDUCED AND DESIGNED TO SUIT SUBJECT TO APPROVAL.