

PLAN 1:100

SECTION A-A

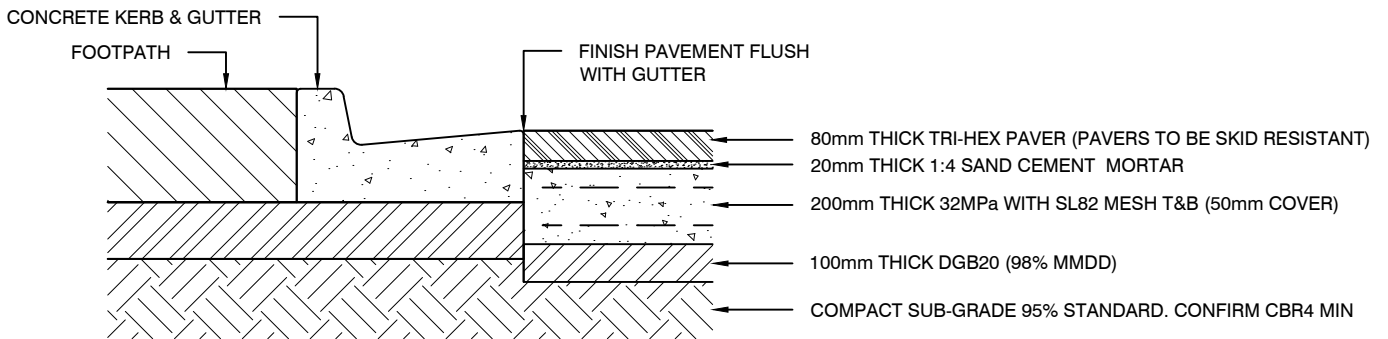

SECTION B-B

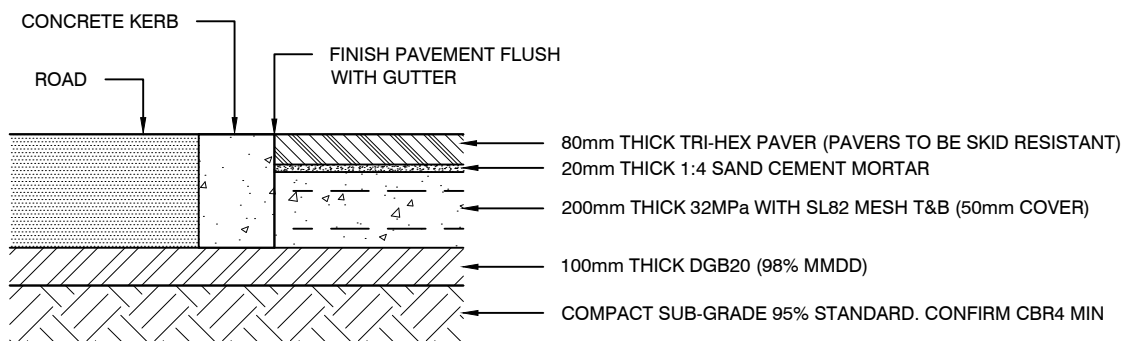

SECTION 1:20

NOTE: ALL DIMENSIONS IN MILLIMETRES UNLESS OTHERWISE STATED