

STEP IRON ARRANGEMENT

ELEVATION 1:10

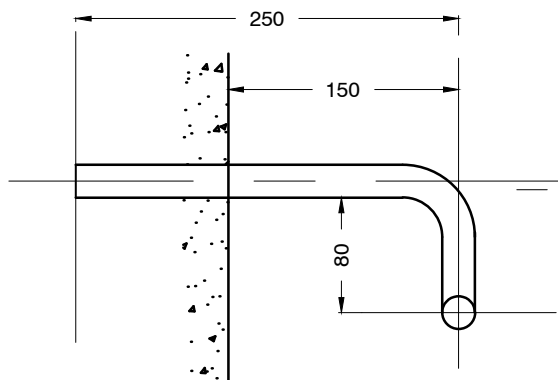

SECTION 1:5

NOTES:

- 1: STEP IRONS TO BE FABRICATED FROM 20mm Ø M.S.
- 2: ALL BENDS TO BE FORMED AROUND 12mm diameter PIN
- 3: STEP IRONS TO BE PROVIDED IN PITS DEEPER THAN 1.0m
- 4: STEP IRONS TO BE HOT-DIPPED GALVANISED
- 5: STEP IRONS TO BE LOCATED DIRECTLY ABOVE PIT OUTLET PIPE