

PLAN

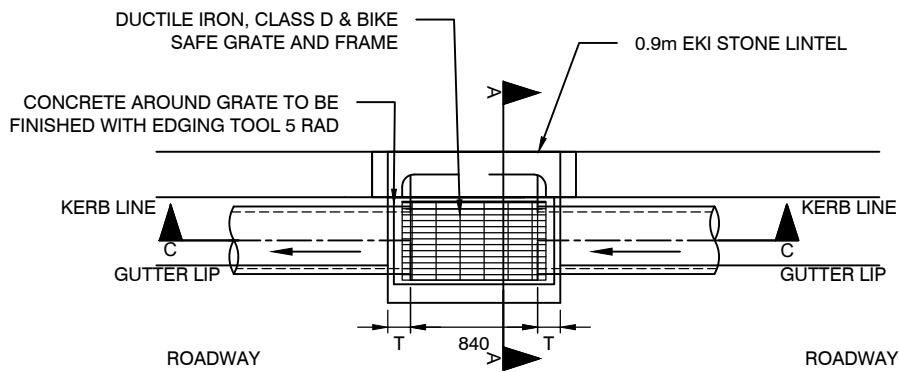

SECTION B-B

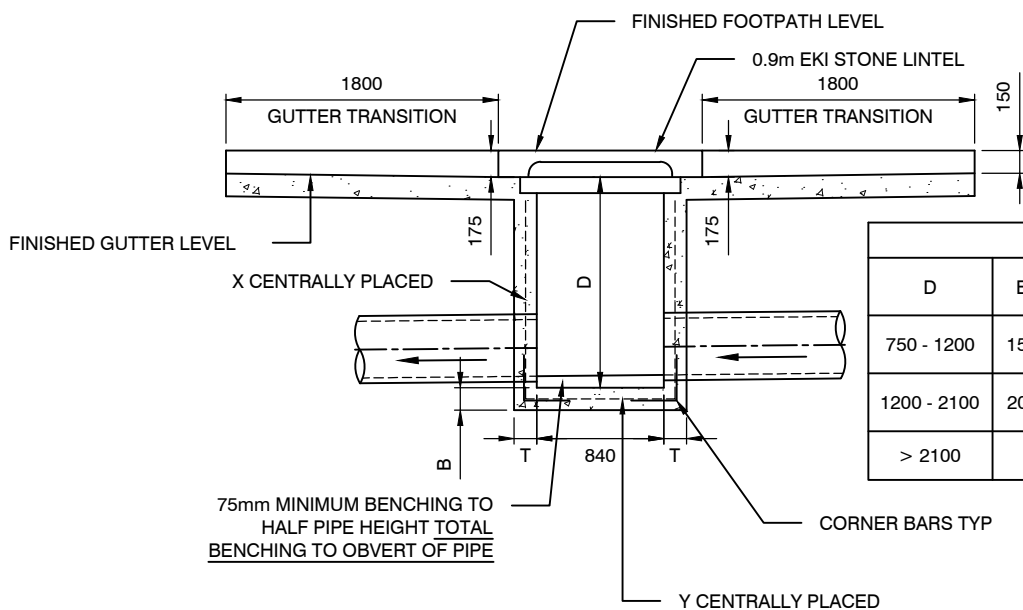

PIT SPECIFICATIONS					
D	B	T	X	Y	CORNER BARS
750 - 1200	150	150	SL82	SL81	N12-300 L 500
1200 - 2100	200	180	SL81	SL81	N12-200 L 600
> 2100	TO STRUCTURAL ENGINEERS SPECIFICATION				

SECTION A-A

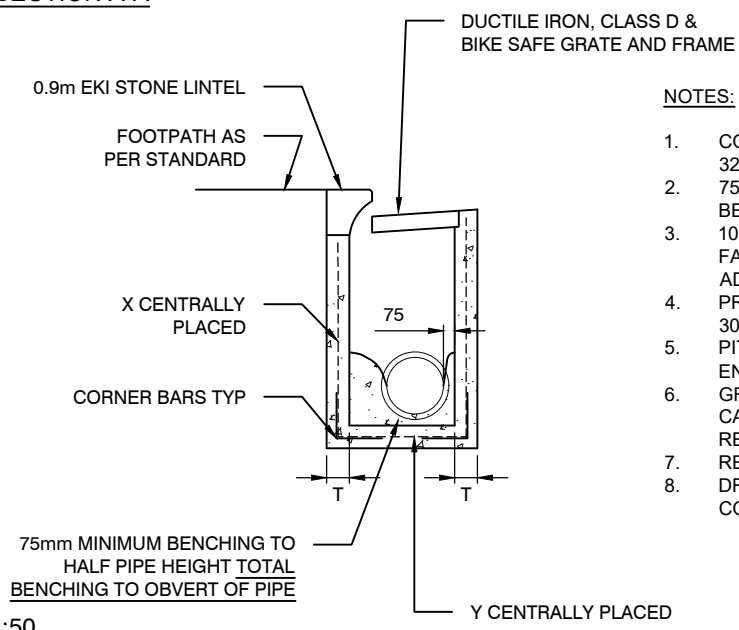

NOTES:

1. COMPRESSIVE STRENGTH OF CONCRETE AT 28 DAYS TO BE 32MPa.
2. 75mm MINIMUM BENCHING TO HALF PIPE HEIGHT TOTAL BENCHING TO OVERTOP OF PIPE.
3. 100mmØ SUBSOIL DRAINAGE PIPE 3.0m LONG WRAPPED IN FABRIC SOCK TO BE PROVIDED IN PIPE TRENCHES ADJACENT TO INLET PIPES.
4. PROVIDE STEP IRONS WHERE PIT IS DEEPER THAN 1.0m AT 300mm CENTRES
5. PITS OVER 2.1m IN DEPTH TO BE DESIGNED BY STRUCTURAL ENGINEER.
6. GRATES SHALL BE BICYCLE SAFE AND HAVE MAXIMUM INLET CAPACITY. ALL GRATES MUST BE APPROVED BY THE CITY'S REPRESENTATIVE.
7. REINFORCEMENT TO COMPLY WITH AS1302, 1303 & 1304.
8. DRAINAGE PIPE TO BE MINIMUM 375Ø CLASS 4 REINFORCED CONCRETE PIPE

SCALE 1:50

NOTE: ALL DIMENSIONS IN MILLIMETRES UNLESS OTHERWISE STATED