

**PLAN**  
1:25

- NOTES:**
1. THIS DRAWING IS TO BE READ IN CONJUNCTION WITH DWG 2.1.4 & 2.1.17
  2. ALL REINFORCEMENT TO COMPLY WITH AS46714
  3. ALL REINFORCEMENT TO BE GRADE 500
  4. COMPRESSIVE STRENGTH OF CONCRETE AT 28 DAYS TO BE 32MPa.
  5. ALL REINFORCEMENT SHALL BE PLACED IN MID-SECTION UNO. OTHERWISE MIN CONCRETE COVER SHALL BE 40mm - B1 COVER
  6. FOR ANY PENETRATION THROUGH WALLS AND SLABS GREATER THAN 200 SPACING, PROVIDE N12 TRIMMER BARS AND ADDITIONAL N12 REPLACEMENT BARS ON EACH SIDE.
  7. LAP LENGTH IS TO BE MINIMUM 40 x BAR Ø UNLESS NOTED OTHERWISE.
  8. 75mm MINIMUM BENCHING TO HALF PIPE HEIGHT TOTAL BENCHING TO OBVERT OF PIPE.
  9. 100mmØ SUBSOIL DRAINAGE PIPE 3.0m LONG WRAPPED IN FABRIC SOCK TO BE PROVIDED IN PIPE TRENCHES ADJACENT TO INLET PIPES.
  10. PROVIDE STEP IRONS WHERE PIT IS DEEPER THAN 1.0m AT 300mm CENTRES.
  11. GRATES SHALL BE BICYCLE SAFE AND HAVE MAXIMUM INLET CAPACITY. ALL GRATES MUST BE APPROVED BY THE CITY'S REPRESENTATIVE.
  12. DRAINAGE PIPE TO BE MINIMUM 375Ø CLASS 4 REINFORCED CONCRETE PIPE

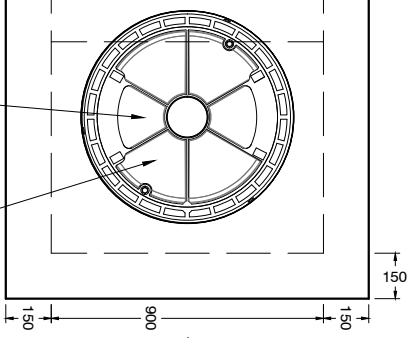

**MANHOLE COVER AND FRAME.**  
NOTE: PIT LID CAN BE CENTRED OR OFF-CENTRED AS REQUIRED

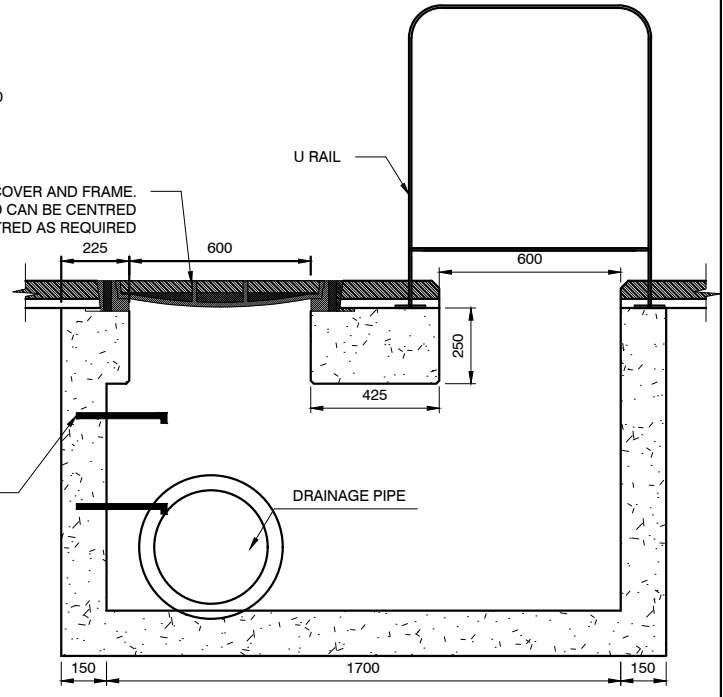

STEP IRONS REQUIRED @300mm SPACINGS IF DEPTH OF PIT IS GREATER THAN 1.0m AS PER STANDARD DETAIL

**SECTION B-B**  
1:25

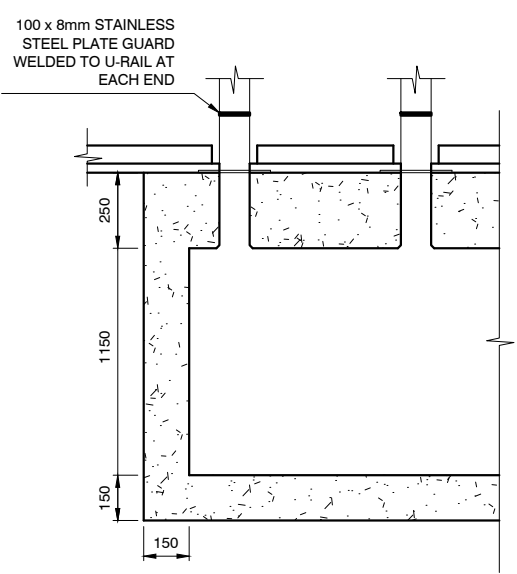

**SECTION A-A**  
1:25

NOTE: ALL DIMENSIONS IN MILLIMETRES UNLESS OTHERWISE STATED