

**PLAN**  
1:100

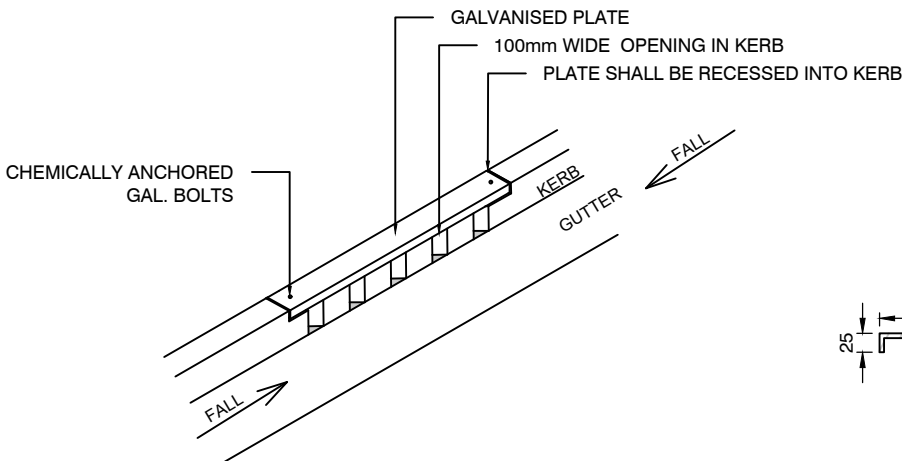

**GALVANISED PLATE DETAIL INSTALLATION DETAIL**  
1:50



**GALVANISED PLATE DETAIL**  
1:10

**NOTE:**

- 1- RAINGARDEN SHALL BE DESIGNED IN ACCORDANCE WITH SYDNEY STREET TECHNICAL SPECIFICATION PART A4.
- 2- SURCHARGE PIT MAY BE DELETED UPON APPROVAL. REFER SYDNEY STREET TECHNICAL SPECIFICATION PART A4.
- 3- THIS OPTION BEST SUITS SMALLER CATCHMENTS WHERE
  - FOOTPATH HAS A GRASS VERGE.
  - INVERTS OF THE EXISTING DRAINAGE PIPES ARE SHALLOWER THAN 1.2m.
- 4- THE DRAINAGE PIT SHALL BE CONSTRUCTED IN ACCORDANCE WITH DRAWINGS #7.1.1 TO #7.1.6.

NOTE: ALL DIMENSIONS IN MILLIMETRES UNLESS OTHERWISE STATED