

RAINGARDEN ENERGY DISSIPATION - PLAN

1:25

NOTE: DISSIPATION BASIN LENGTH SHALL BE MINIMUM 400mm UNLESS NOTES OTHERWISE.

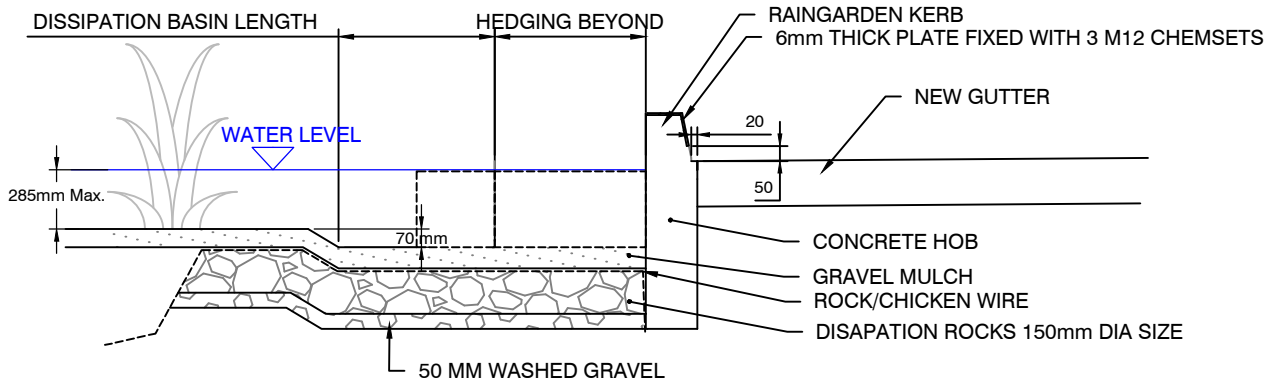

SECTION

1:10

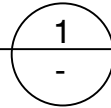

NOTE: THE PLATE SHALL BE RECESSED INTO THE KERB

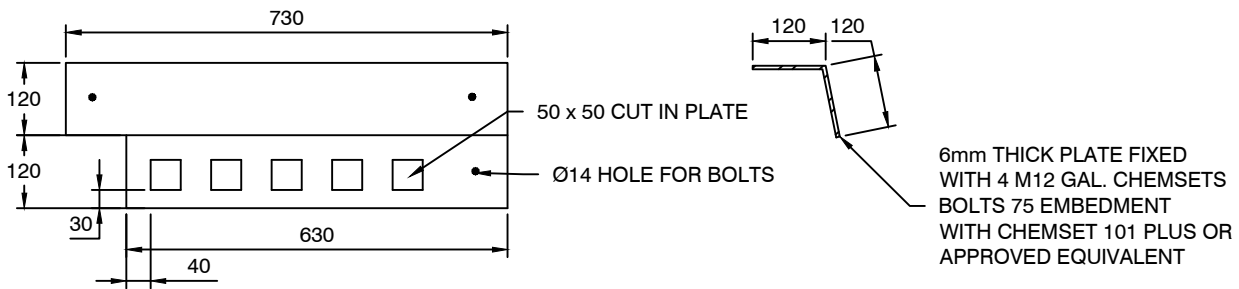

GALVANISED PLATE

1:10

NOTE: T - TERRACE GARDEN IS THE PREFERRED OPTION FOR MOST OF RAINGARDENS EXCEPT ROCK SWALES: IN WHICH CASE ENTRY STRUCTURE SHALL BE DESIGNED TO SUIT THE ROCK SWALE

NOTE: ALL DIMENSIONS IN MILLIMETRES UNLESS OTHERWISE STATED