

PLAN
1:20

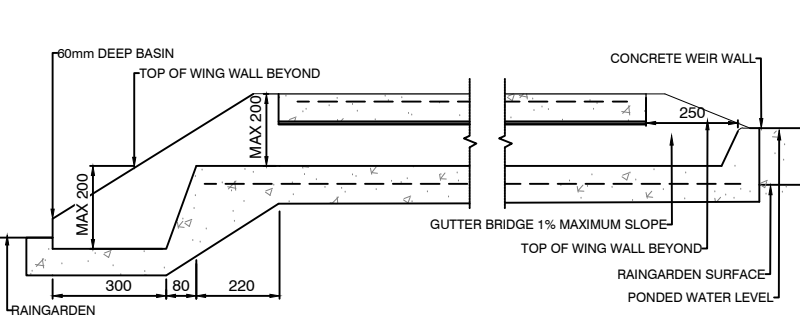

SECTION A-A
1:20

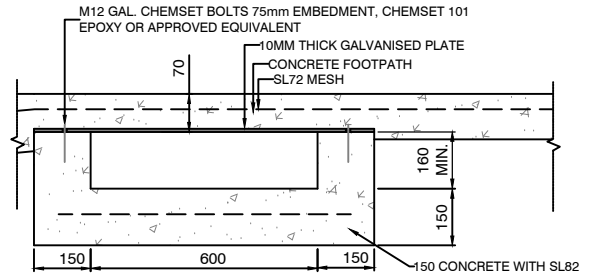

SECTION B-B
1:20

CONCRETE GUTTER BRIDGE

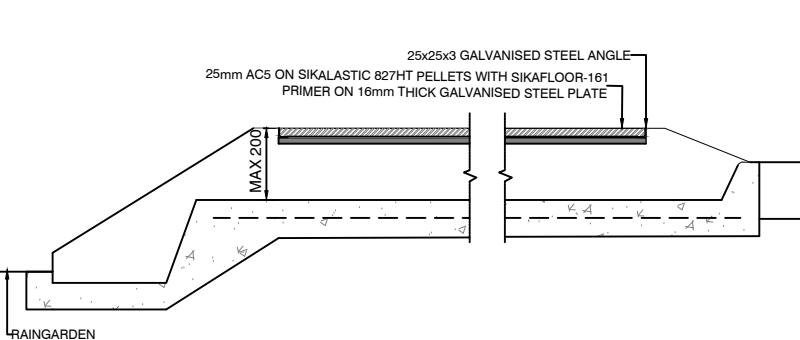

SECTION A-A
1:20

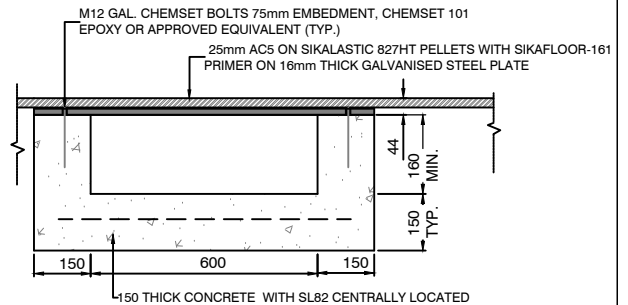

SECTION B-B
1:20

ASPHALT GUTTER BRIDGE

NOTES:

1. GUTTER BRIDGE SHALL BE DESIGNED TO SUIT MINIMUM 5 YEARS ARI STORM & SHALL HAVE 240 kN ULTIMATE LOAD CAPACITY. DESIGNER SHALL SUBMIT MAINTENANCE REGIME WITH ANY RAINGARDEN INCORPORATED IN DESIGN.
2. USE OF BONDEK IS NOT ALLOWED FOR GUTTER BRIDGES.
3. SIZE OF GUTTER BRIDGE SHALL BE DESIGNED TO SUIT THE ANTICIPATED FLOW RATES

NOTE: ALL DIMENSIONS IN MILLIMETRES UNLESS OTHERWISE STATED