

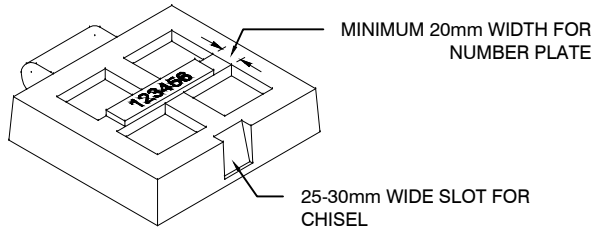

LID (UNDERSIDE)

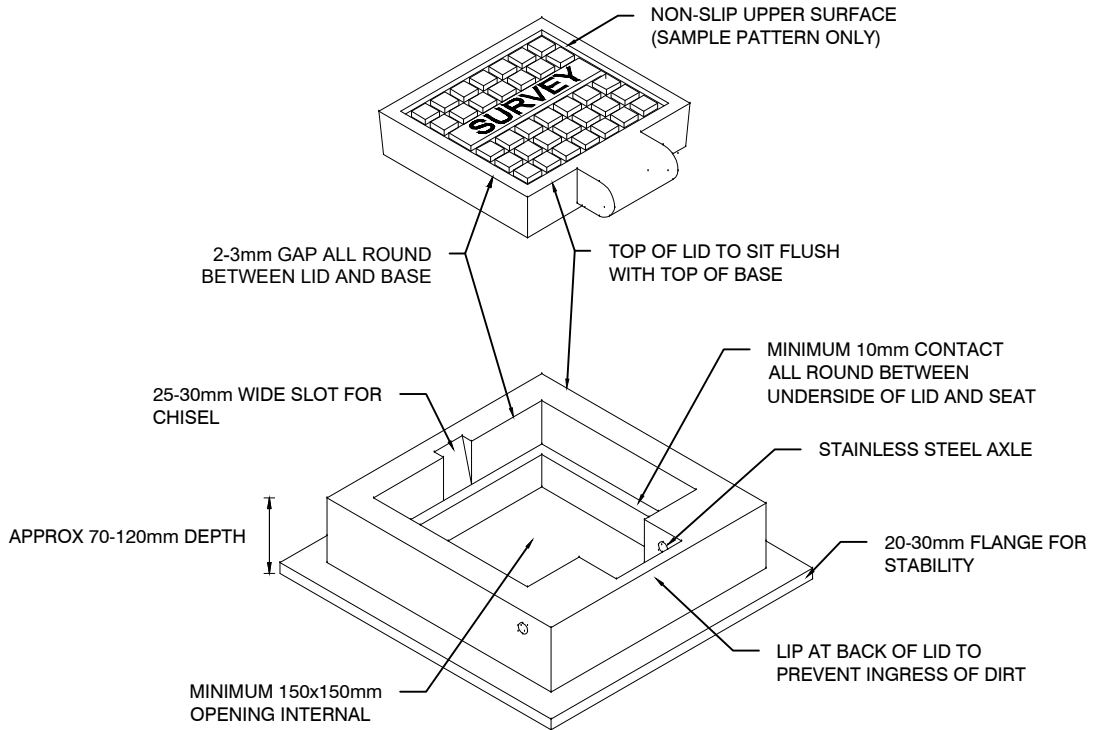

LID (TOPSIDE)



FRAME

SECTION 1:10

NOTE: ALL DIMENSIONS IN MILLIMETRES UNLESS OTHERWISE STATED