

NOTE:

1. WHEREVER POSSIBLE FIXTURES SHOULD BE LOCATED TO ALIGN FIXING POINTS WITH PAVING JOINTS TO MIMIMISE CUTTING THROUGH PAVING UNITS. SET FIXTURES FURTHER APART (CLEARANCE MIN. 300 mm) AS REQUIRED TO ALIGN WITH PAVING JOINTS.
2. SUFFICIENT SPACE SHOULD BE ALLOWED BETWEEN FIXTURES ACCOMMODATE BELOW GROUND FOOTING AND FIXINGS.
3. ALLOW FOR MORE ADEQUATE CLEARANCE IN RELATION TO FIXTURE USAGE AS REQUIRED.
4. EG. AT TELEPHONE BOOTHS AND FOR BIKE RACK/RING.
5. FIXTURES SHOULD BE LIMITED IN CLOSE PROXIMITY TO PEDESTRIAN CROSSING POINTS TO MINIMISE OBSTRUCTION.

PLAN 1:100

NOTE: ALL DIMENSIONS IN MILLIMETRES UNLESS OTHERWISE STATED

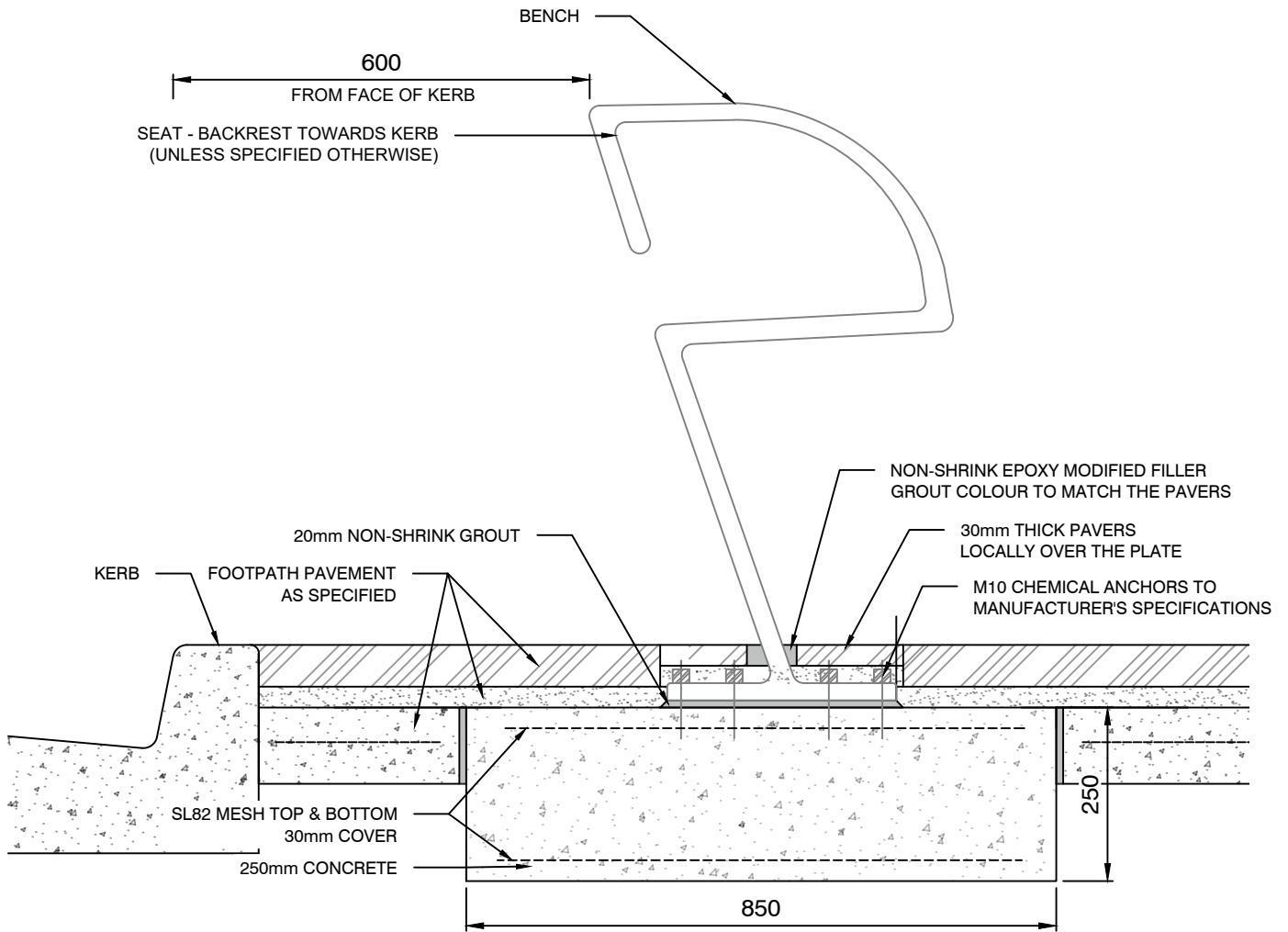

SECTION
1:10

NOTE: ALL DIMENSIONS IN MILLIMETRES UNLESS OTHERWISE STATED

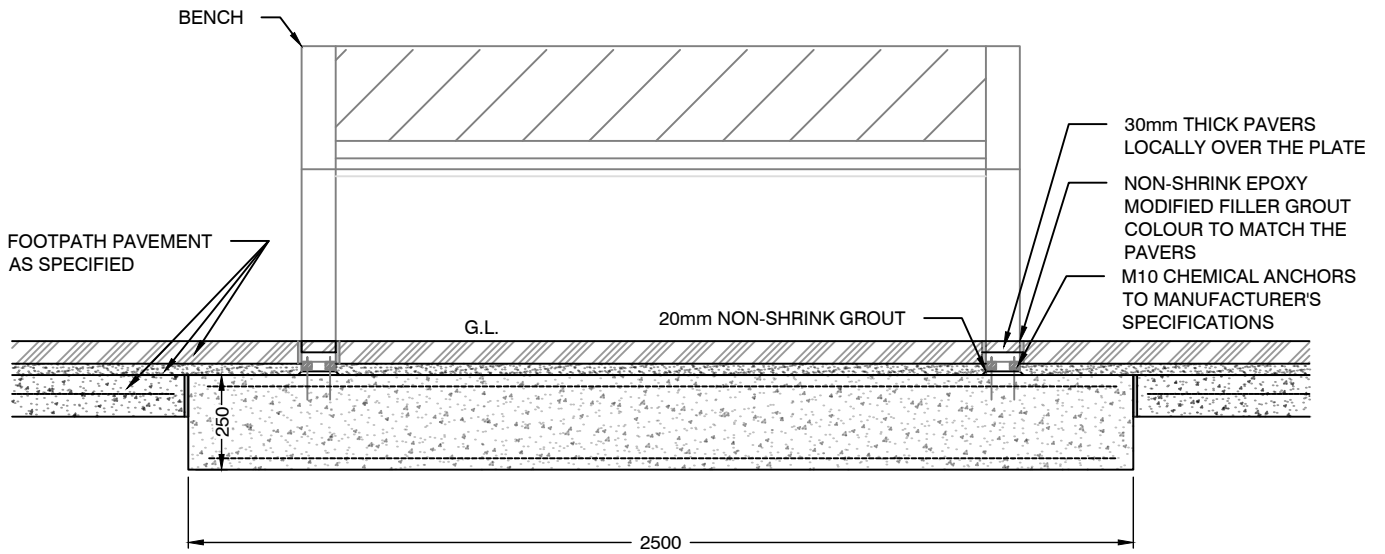

SECTION
1:20

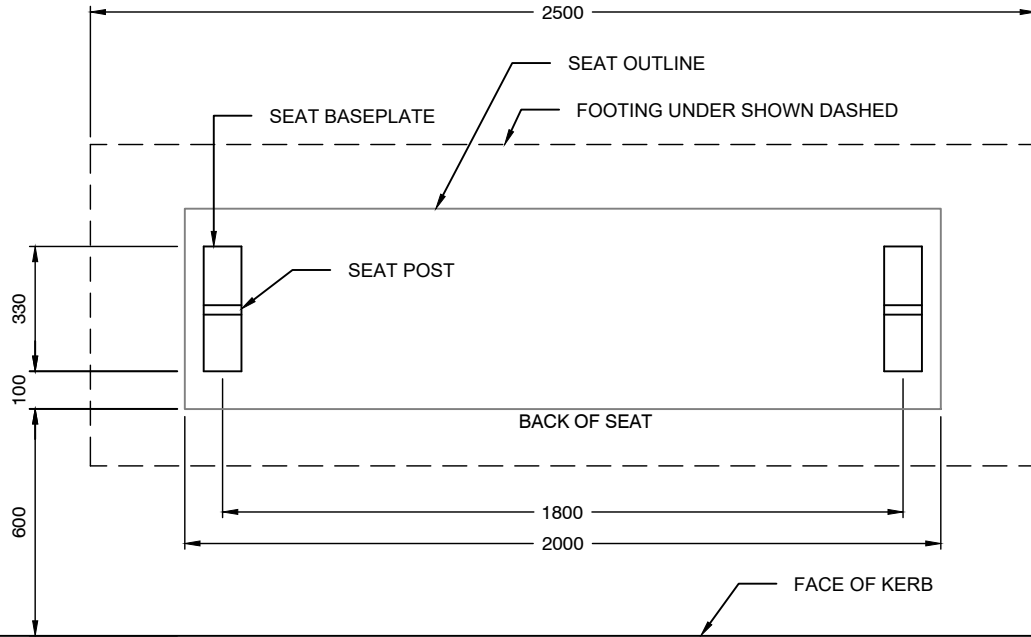

PLAN
1:20

NOTE: ALL DIMENSIONS IN MILLIMETRES UNLESS OTHERWISE STATED

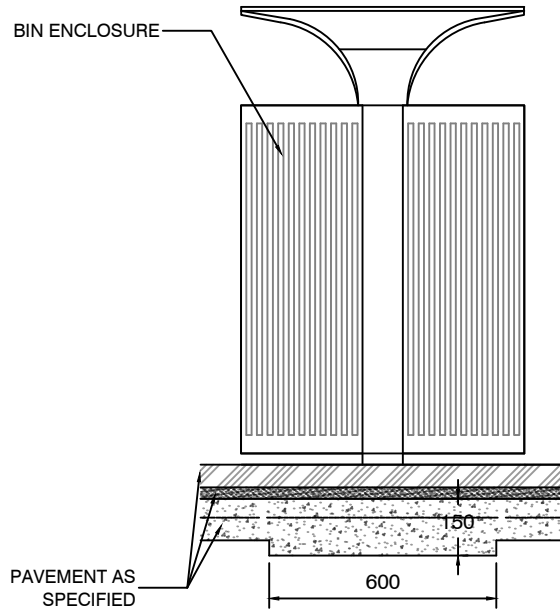
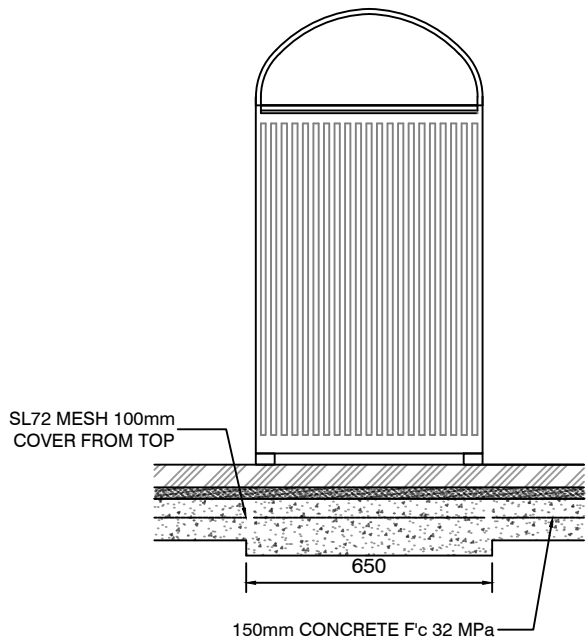

VIEWS
1:20

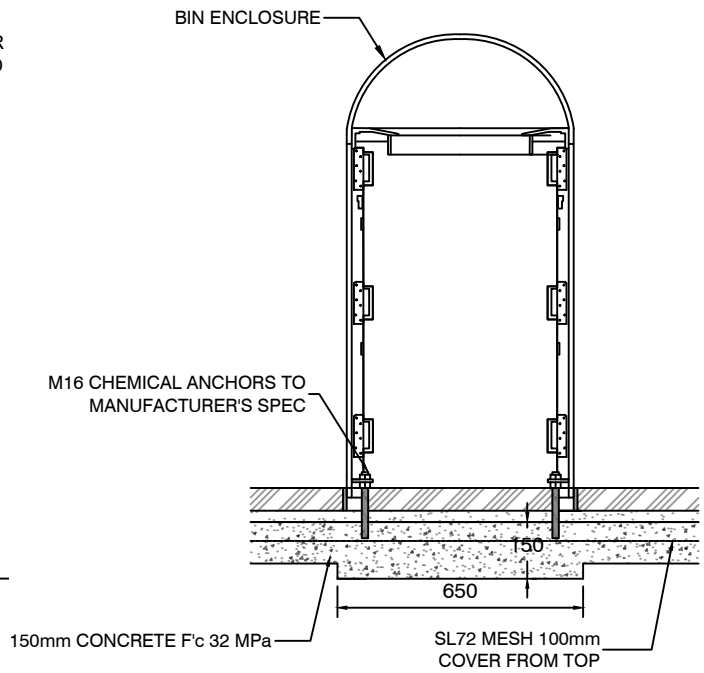
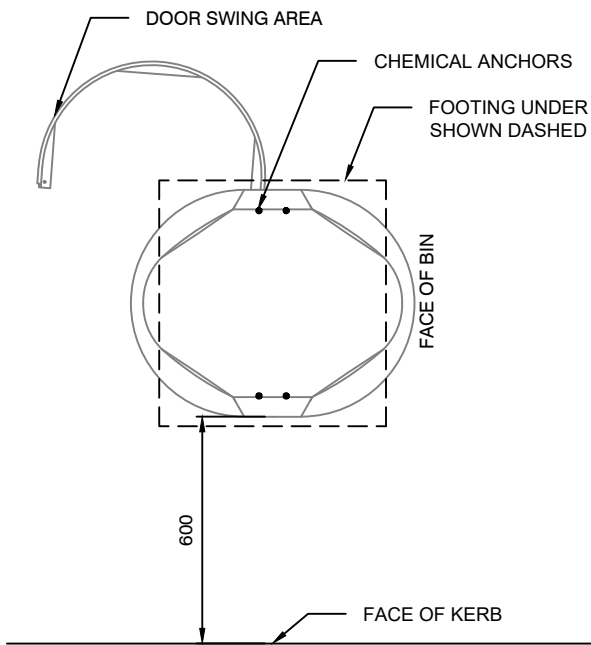

PLAN
1:20

SECTION
1:20

NOTE: ALL DIMENSIONS IN MILLIMETRES UNLESS OTHERWISE STATED

INSTALLATION DETAIL 1

INSTALLATION DETAIL 2

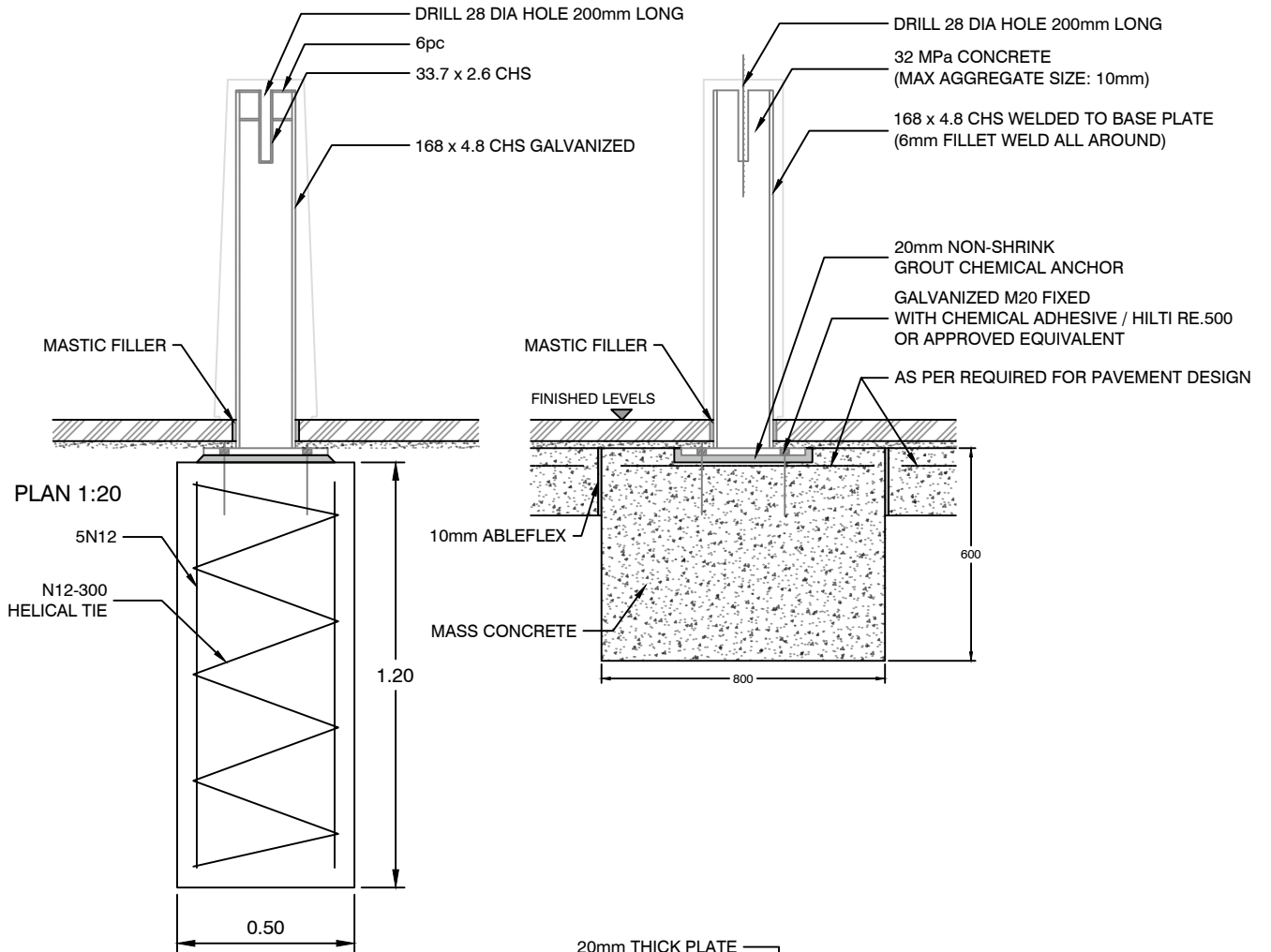

NOTE: ALL DIMENSIONS IN MILLIMETRES UNLESS OTHERWISE STATED

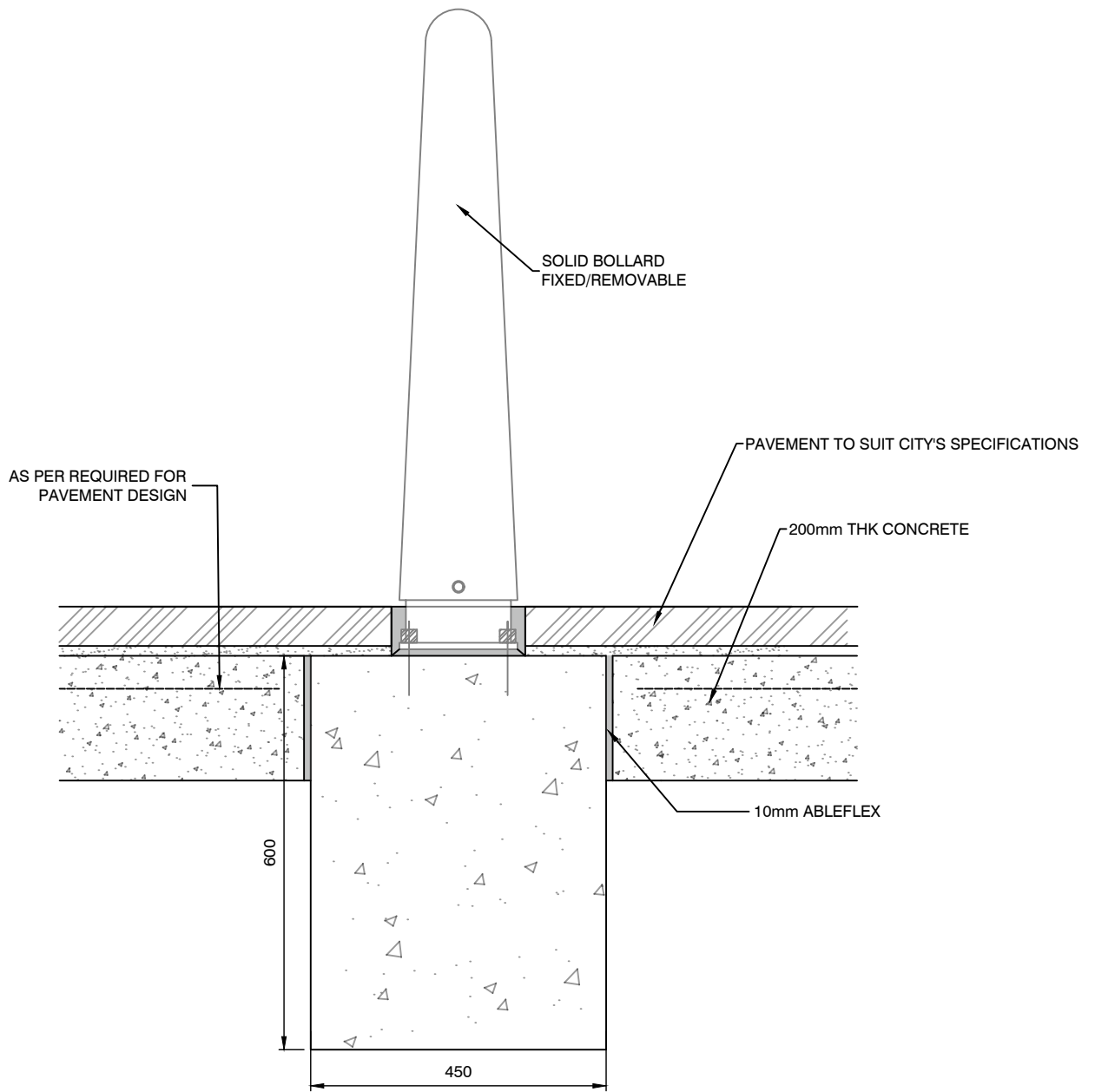

SECTION 1:10

NOTE: ALL DIMENSIONS IN MILLIMETRES UNLESS OTHERWISE STATED

FIXED BOLLARD

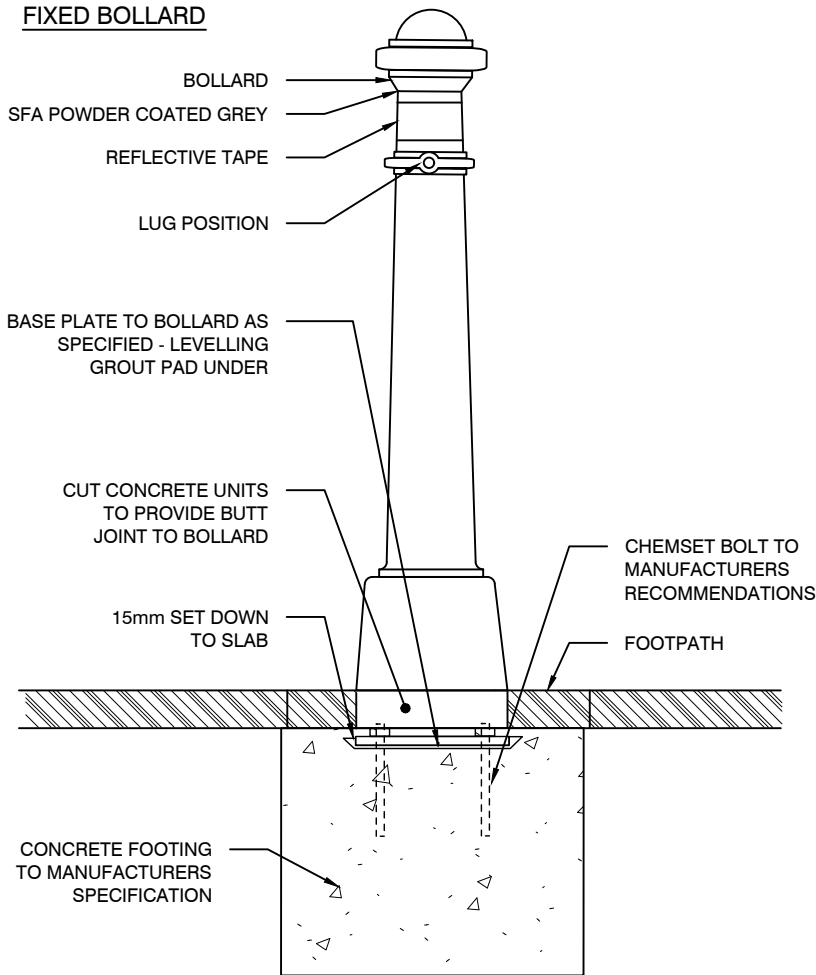

PAVEMENT SOCKET PLAN

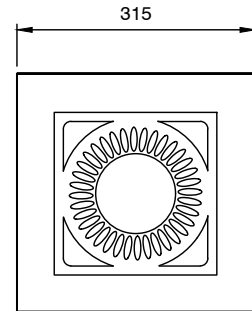

REMOVABLE BOLLARD

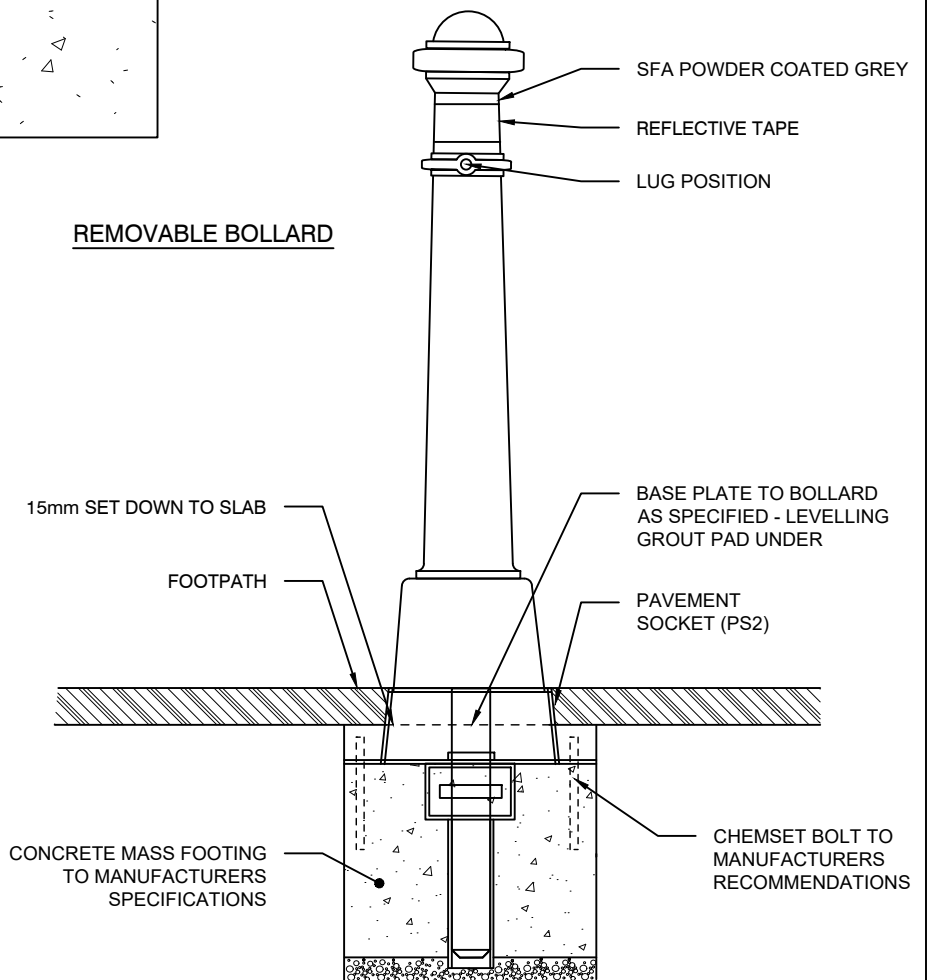

PAVEMENT SOCKET ELEVATION

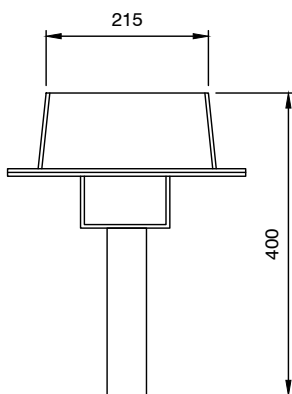

SCALE 1:10

NOTE: ALL DIMENSIONS IN MILLIMETRES UNLESS OTHERWISE STATED

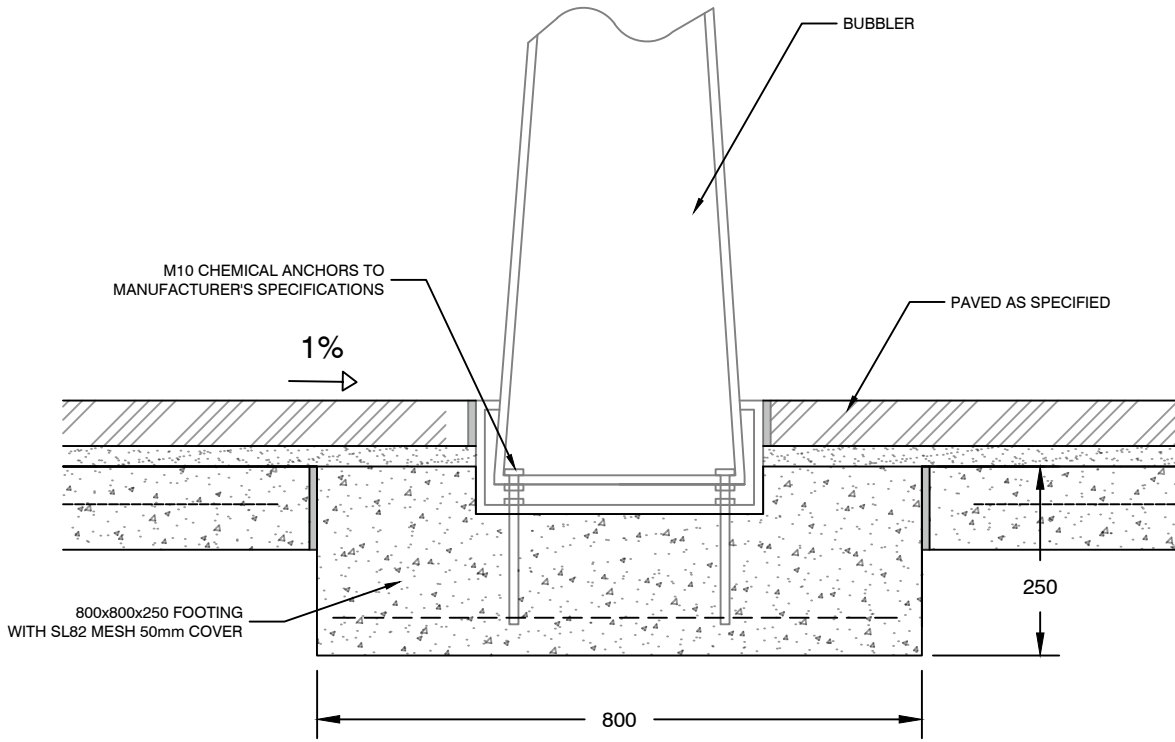

FRONT VIEW

SECTION 1:10

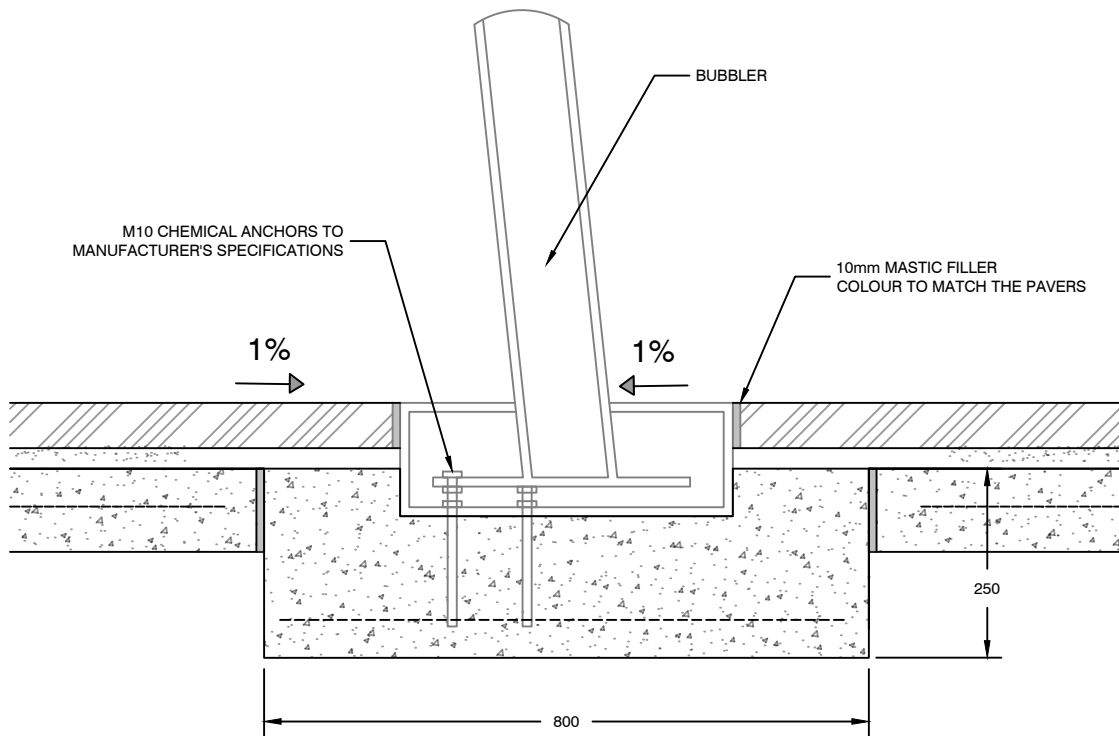

SIDE VIEW

NOTE: ALL DIMENSIONS IN MILLIMETRES UNLESS OTHERWISE STATED